

aquawa[®]

SCOOTER

enjoy

L'UNICO DAL 1978

THE ONLY ONE SINCE 1978



AS650 CE -1-ONE

AS650 CE SUPERMAGNUM

CATALOGO RICAMBI - LISTINO PREZZI 2020

SPARE PARTS CATALOG - PRICE LIST 2020

n°2

enjoy

MADE IN ITALY



ENJOY s.a.s. via Storchi 2/b, 42011 -Bagnolo in Piano (Reggio Emilia) -ITALY

Tel. +39 0522 706329 E-mail : info@aquascooter.it Web site : www.aquascooter.it

AQUASCOOTER AS650 -1-ONE - AS650 SUPERMAGNUM

INDICE - INDEX

CONDIZIONI GENERALI DI VENDITA - GENERAL SALES CONDITIONS	PAG. 2
INTRODUZIONE - INTRODUCTION	PAG. 3
CARATTERISTICHE TECNICHE - TECHNICAL FEATURES	PAG. 4
INDICAZIONI GENERALI - GENERAL INSTRUCTION	PAG. 5
GARANZIA - WARRANTY	PAG. 6
RICAMBI - SPARE PARTS : GRUPPO ALBERO MOTORE (disegno 1) - CRANK SHAFT GROUP (drawing 1)	PAG. 7 - 8
RICAMBI - SPARE PARTS : GRUPPO BASAMENTO/CILINDRO/ELICA (disegno 2) - CRANK CASE/CYLINDER/PROPELLER GROUP (drawing 2)	PAG. 9 - 10
RICAMBI - SPARE PARTS : GRUPPO MARMITTA, CONVOGLIATORE E PROTEZIONE ELICA (disegno 3) - MUFFLER GROUP, WATER CONVEYOR, PROPELLER GUARD (drawing 3)	PAG. 11 - 12
RICAMBI - SPARE PARTS : GRUPPO ACCENSIONE (disegno 4) - IGNITION GROUP (drawing 4)	PAG. 13 - 14
RICAMBI - SPARE PARTS : GRUPPO CARBURATORE (disegno 5) - CARBURETTOR GROUP (drawing 5)	PAG. 15 - 16
RICAMBI - SPARE PARTS : GRUPPO AVVIAMENTO (disegno 6) - STARTER GROUP (drawing 6)	PAG. 17 - 18
RICAMBI - SPARE PARTS : GRUPPO IMPUGNATURA E COLLETTORE ASPIRAZIONE (disegno 7) - CRUISE HANDLE GROUP AND AIR INLET HOSE (drawing 7)	PAG. 19 - 20
RICAMBI - SPARE PARTS : GRUPPO SERBATOIO CON TUBI (disegno 8 - 9) - FUEL TANK GROUP WITH TUBES (drawing 8 - 9)	PAG. 21 - 24
RICAMBI - SPARE PARTS : SNORKEL E ADESIVI MODELLO (disegno 10) - SNORKEL AND STICKERS (drawing 10)	PAG. 25 - 26
RICAMBI - SPARE PARTS : KIT ADESIVI AVVERTENZE - WARNING STICKERS KIT	PAG. 27 - 28
RICAMBI - SPARE PARTS : KIT GUARNIZIONI E LUBRIFICANTI - GASKET KITS AND LUBRICANTS	PAG. 29 - 30
RICAMBI - SPARE PARTS : ATTREZZATURE - TOOLS	PAG. 31 - 36
ACCESSORI - ACCESSORIES	PAG. 37 - 40
NUMERO DI SERIE, MANUALI E AVVERTENZE - SERIAL NUMBER, USER MANUAL AND WARNINGS	PAG. 41 - 42
CONTENUTO DEGLI IMBALLI - PACKAGING CONTENTS	PAG. 43 - 46
GALLERIA - GALLERY	PAG. 47
NOTE - NOTES	PAG. 48
INFORMAZIONI GENERALI E PREZZI - GENERAL INFO AND PRICES	PAG. 49

*** LA NUMERAZIONE DEI COMPONENTI (Pos.) E' PROGRESSIVA

*** THE NUMBERING OF THE COMPONENTS (Pos.) IS PROGRESSIVE

CONDIZIONI GENERALI DI VENDITA

Vi preghiamo di leggere attentamente le condizioni generali di vendita, in quanto ENJOY s.a.s. non risponde di errori causati dalla non conoscenza o inosservanza delle stesse.

- I Prezzi del presente listino si intendono in valuta euro ,unitari , al netto di IVA e franco fabbrica . Eventuali imballi extra sono addebitati al costo .
- Le ordinazioni vengono accettate da ENJOY s.a.s. ,solo se formulate per iscritto, specificando i codici e le quantità per ogni singolo articolo.
- Tutte le spedizioni saranno effettuate in porto assegnato o franco fabbrica .

Sarà pertanto cura del cliente far valere le ragioni al trasportatore per eventuali rotture o smarrimenti.

Nel caso si verificano, è assolutamente necessario sottoscrivere una riserva scritta e foto al corriere ed inoltrarne una copia ad ENJOY s.a.s.

Rimane inteso che i reclami per rotture, danneggiamento, smarrimento potranno essere valutate da ENJOY s.a.s. , solo se pervenute entro 8 giorni dal ricevimento della merce.

- I termini di consegna indicati vengono rispettati compatibilmente con la disponibilità aziendale; eventuali ritardi non danno comunque diritto a richiedere indennizzi da parte dei clienti.
- Tutti i pagamenti dovranno essere eseguiti direttamente a ENJOY s.a.s. .
- **Per i pagamenti non effettuati entro i termini concordati verranno addebitati gli interessi di mora + spese, conformi al D.L.GS 231/2002 della normativa 2000/35/CE e gli ordini in corso saranno immediatamente sospesi e quelli successivi saranno evasi solo tramite pagamento anticipato .**
- La merce inviata a ENJOY s.a.s. per controlli, revisioni o riparazioni dovrà essere accompagnata da regolare documento di trasporto con indicazione del numero di matricola del prodotto e pervenire in porto franco. E' indispensabile inoltre una descrizione dei problemi o guasti riscontrati al fine di facilitare le operazioni di riparazione.
- **Per procedere alla riparazione, i preventivi dovranno essere rispediti firmati per accettazione da parte del cliente.**
- **In caso contrario il materiale sarà reso smontato e verranno addebitate € 35,00 per oneri di spese di controllo e gestione dello stesso da parte di ENJOY s.a.s. al cliente.**
- I costi delle riparazioni e/o sostituzioni in garanzia saranno sostenuti da ENJOY s.a.s. solo ed esclusivamente dopo verifica di un tecnico ENJOY s.a.s. presso la sede della stessa.
- Si accettano resi solo se autorizzati per iscritto da ENJOY s.a.s.
- ENJOY s.a.s. non si assume nessuna responsabilità per fermi derivanti da ritardi nella consegna o riparazione della merce.
- Per qualsiasi controversia si elegge come competente il foro di Reggio Emilia.

La ENJOY s.a.s. si riserva il diritto di apportare ai propri prodotti modifiche tecniche e di prezzo senza alcun preavviso.

GENERAL SALES CONDITIONS

Please read the general conditions of sale carefully, as ENJOY s.a.s. is not responsible for errors caused by non-knowledge or non-compliance with the same.

- The prices of this price list are in euro currency understood to be unitary and net of VAT and ex-works. **Any extra packaging are charged at the cost .**
- Orders are accepted by ENJOY s.a.s. , in writing, specifying item codes and quantities for each item.
- All shipments will be carried ex works Bagnolo in Piano.

The goods, supplied always travel at the risk and cost of the customer.

It is therefore customer's responsibility to assert the reasons to the carrier for any breakages or losses.

In the event that they occur, it is absolutely necessary to sign a written complain and photos to the carrier and send a copy to ENJOY s.a.s.

It is understood that claims for breakage, damage, loss can be evaluated by ENJOY s.a.s. only if received within 8 days of receipt of goods.

- Delivery times are respected compatibly with company availability , and delays do not however give the right to request refunds by customers.
- All payments must be made directly to ENJOY s.a.s.
- **For payments made out of the agreed terms, default interest will be charged + expenses, in compliance with the D.L.GS 231/2002 of the 2000/35/CE regulation and the orders in progress will be immediately suspended and following ones will be dealt only with prepayment.**
- The goods sent to ENJOY s.a.s. for service or repairs must be travel by a regular delivery note indicating the serial number of the product and shipped free of charge . A description of the possible problems or faults facilitates repair operations and lower costs .
- **To proceed with the repair, the estimates made by ENJOY s.a.s. must be returned signed for acceptance by customers.**
- **In case reparation budget won't be accepted , AQUASCOOTER is returned disassembled and € 35,00 will be charged for checks and management costs.**
- The costs of repairs and/or replacement under warranty will be borne by ENJOY s.a.s. only and exclusively after audit of ENJOY technician.
- Returns are accepted only if authorized in writing by ENJOY s.a.s.
- ENJOY s.a.s. does not assume any responsibility for stops, resulting from delays in delivery or repair of the goods.
- For any controversy the Court of Reggio Emilia is elected as competent.

ENJOY s.a.s. reserves the right to make necessary changes to its products without notice.

AQUASCOOTER AS650 -1-ONE - AS650 SUPERMAGNUM

INTRODUZIONE - INTRODUCTION

L'AQUASCOOTER ENJOY è un prodotto unico nel suo genere, progettato e costruito prestando la massima cura alla salute e alla sicurezza dell'utilizzatore ed alla salvaguardia dell'ambiente. Utilizzando il nuovo carburante ab ALKILAT benzina miscela 2% inodore e senza emissioni di fumo, renderete il vostro AQUASCOOTER ECOLOGICO .ab ALKILAT benzina rispetta i requisiti delle normative SN181163 svizzere e lo standard svedese SS155461 Rispetta le norme CE, se lo lasci in moto non scappa perché ti gira intorno, pesa solo 7,4 Kg e ha un ingombro limitato.

Nessun' altra macchina è così versatile; si presta a svariati utilizzi per il divertimento, è facile da usare, galleggia, è sicuro e silenzioso.

E' un semplice motore a due tempi, che vi offrirà molte ore di svago se usato e mantenuto correttamente.

E' stato studiato per uso hobbistico e non come strumento di lavoro. Può arrivare ad una velocità di 8-10Km/h.

AQUASCOOTER ENJOY is a unique product, designed and built with attention to personal health, safety and also to enviromental safeguard.

ECO-FRIENDLY AQUASCOOTER ENJOY is possible by using the new AB ALKILAT gasoline (mix 2%), thanks to odour-free and very low carbon.

Ab- ALKILAT gasoline complies with Swiss requirements: SN181163 and Swidish standards: SS155461, plus CEE and EPA standards.

Leaving Aquascooter on in the water runs you around and doesn't run away . It weighs only 7 Kg and its size is smaller than usual.

No other machine is so versatile ; it is suitable for many fun purposes, easy to use floats, secure and soundless.

It is a simple two-stroke engine that will give you many hours of fun if used and kept correctly.

Specifically designed for hobby activities, it is not a working tool. It can reach a speed of 8-10Km per hour.

PUO' ESSERE USATO - IT CAN BE USED :



CARATTERISTICHE TECNICHE - TECHNICAL FEATURES

MODELLO-MODEL

Motore - Engine

Cilindrata

Displacement

Alesaggio-Corsa

Bore - Stroke

Albero motore

Crank shaft

Spinta dell'elica

Propeller thrust

Potenza motore

Engine power

Velocità traino con 70Kg.

Towing speed with 70Kg.

Carburante

Fuel

Tipo di olio

Oil type

Capacità serbatoio

Fuel tank capacity

Accensione

Ignition

Candela

Spark plug

Avviamento

Starting

Autonomia media

Fuel range

Peso a secco

Dry weight

AS650 -1-ONE

2 tempi a presa diretta -2 stroke direct drive

49cc.

49cc.

40 x 39mm

40 x 39mm

con contrappeso a mannaia

AX counterweight type

22Kg.

22Kg.

1,47Kw (2HP) a 4600g/min

1,47Kw (2HP) at 4600rpm

8Km/h

8Km/h

Miscela benzina /oilo 1,5%

Mixture gasoline/oil 1,5%

completamente sintetico/biodegradabile

fully synthetic/biodegradable

2 Litri

2 Liters

Elettronica CDI

Electronic CDI

Bosch-NGK

Bosch -Ngk

A strappo

Pull start

2 ore

2 hours

7,4Kg.

7,4Kg.

AS650 SUPERMAGNUM

2 tempi a presa diretta -2 stroke direct drive

51,5cc.

51,5cc.

41 x 39mm

41 x 39mm

con contrappeso circolare

Circular counterweight type

25Kg.

25Kg.

1,75Kw (2,4HP) a 5000g/min

1,75Kw (2,4HP) at 5000rpm

10Km/h

10Km/h

Miscela benzina /oilo 1,5%

Mixture gasoline/oil 1,5%

completamente sintetico/biodegradabile

fully synthetic/biodegradable

2 Litri

2 Liters

Elettronica CDI

Electronic CDI

Bosch - NGK

Bosch - Ngk

A strappo

Pull start

1 ora e 50 minuti

1 hour and 50 minutes

7,6Kg.

7,6Kg.

PER RENDERE IL TUO MOTORE ECOLOGICO utilizza BENZINA ALCHILATA AB ALKYLAT BENZIN, miscela 2-T al 2% di olio ad alte prestazioni,completamente sintetico e biodegradabile.E' pronta all'uso.Questo carburante rispetta le norme SN 181163 della Svizzera e lo standard Svedese SN 15 54 61. WWW.BENZINA-ALCHILATA.IT Ambiente e salute delle persone ringrazieranno per l'uso di AB ALKYLAT BENZIN,nonché i vostri motori potranno ringiovanire e richiedere minore manutenzione negli anni. **MAKE YOUR ENGINE ENVIRONMENTALLY FRIENDLY** , use ALKYLAT BENZIN ALCHYLATED PETROL, which is a 2-T mixture with 2% of fully synthetic and biodegradable high performance oil. It is ready for use.

This type of fuel complies with the SN 181163 standards of Switzerland and the Swedish standard SS 15 54 61. WWW.BENZINA-ALCHILATA.IT Environment and human health will thank for the use of AB ALKYLAT BENZIN, as well as your engines that will be able to rejuvenate and require less maintenance over the years.

AVVERTENZE E INDICAZIONI GENERALI - WARNINGS AND GENERAL INSTRUCTIONS

Utilizzare esclusivamente ricambi e attrezzature originali ENJOY s.a.s.

Use only original ENJOY s.a.s. spare parts and tools .

Utilizzare esclusivamente olio per miscela Aquascooter BIODEGRADABILE .

Use only Aquascooter - BIODEGRADABLE oil for mixture .

Leggere sempre attentamente i libretti di uso e manutenzione prima di utilizzare i prodotti mostrati in questo catalogo

Before using the products shown in this catalogue, read carefully the operating and maintenance manual (owner's manual)

Non utilizzare l'AQUASCOOTER senza il "CONVOGLIATORE ACQUA" (Pos.47) e la "GRIGLIA DI PROTEZIONE" (Pos.50) .

Do not use the AQUASCOOTER without the "WATER CONVEYOR" (Pos.47) and the "SAFETY GRID" (Pos.50) .

Non utilizzare l'AQUASCOOTER senza gli adesivi avvertenze (Pos.170) .

Do not use the AQUASCOOTER without the "WARNING STICKERS KIT" (Pos.170) .

L'AQUASCOOTER è auto galleggiante ma non deve essere usato come salvagente .

AQUASCOOTER is self-floating but it must not be used as a life jacket .

Prendete nota delle seguenti indicazioni :

Please pay attention to the following warnings :



=

OLIARE : Utilizzare olio miscela per motori 2T biodegradabile .

OIL : *Use mixture 2T oil and biodegradable .*



=

OLIARE : Utilizzare olio silconico per non rovinare la gomma .

OIL : *Use silicon oil to avoid damage to the rubber .*



=

INGRASSARE : Utilizzare grasso per cuscinetti/ingranaggi tipo EP 1 .

GREASE : *Use bearings/gears grease type EP 1 .*



=

INGRASSARE : Utilizzare grasso PTFE al LITIO .

GREASE : *Use LITIUM PTFE grease .*



=

APPLICARE SIGILLANTE : Utilizzare sigillante LOCTITE 510 .

APPLY SEALANT : *Use sealant LOCTITE 510 .*

Per eventuali riparazioni contattare un centro assistenza più vicino.

For any repairs contact a nearest service center .

AQUASCOOTER AS650 -1-ONE - AS650 SUPERMAGNUM (disegno 1) - (drawing 1)

1 AQUASCOOTER AS650 -1-ONE - AS650 SUPERMAGNUM

ALBERO MOTORE PER AS650 -1-ONE
PER CILINDRO D.40
FOR CYLINDER D.40

1

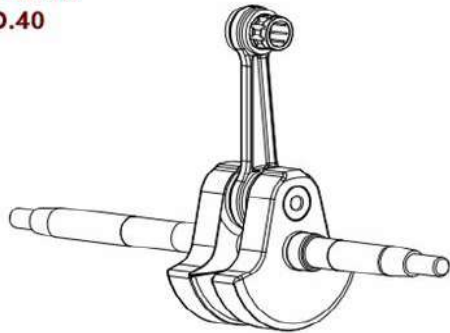

ALBERO MOTORE PER AS650 SUPERMAGNUM
PER CILINDRO D.41
FOR CYLINDER D.41

2

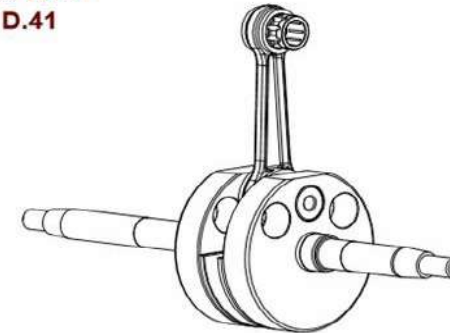

BIELLA PER AS650 -1-ONE
PER CILINDRO D.40
FOR CYLINDER D.40

3

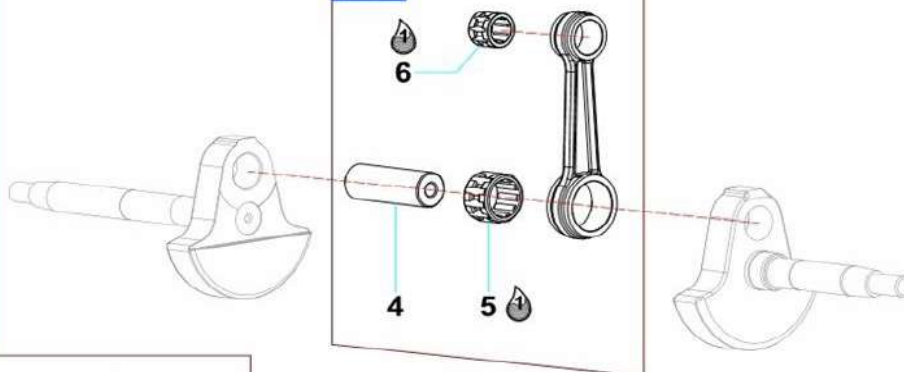

BIELLA PER AS650 SUPERMAGNUM
PER CILINDRO D.41
FOR CYLINDER D.41

3

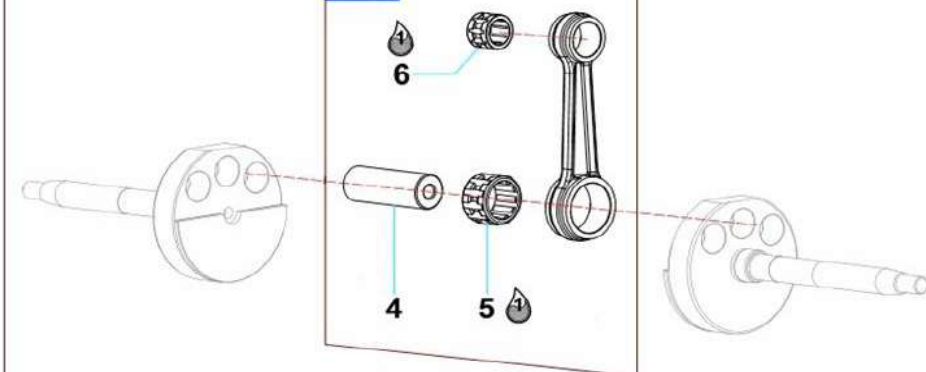

AQUASCOOTER AS650 -1-ONE - AS650 SUPERMAGNUM (disegno 1) - (drawing 1)

Pos.	Cod.	Descrizione	Description	Qt.	Unit Price €
1	70002032	Albero motore compl. AS650 -1-ONE con gabbia piede	AS650 -1-ONE Complete crankshaft with cage	1	140,00
2	70002043	Albero motore compl. AS650 SM con gabbia piede	AS650 SM Complete crankshaft with cage	1	160,00
3	70001110	Biella completa con gabbia pied D.40/D.41	Complete conrod with cage D.40/D.41	1	53,90
4	70001141	Asse accoppiamento D.14xD.6x37	Crankpin D.14xD.6x37	1	10,80
5	70001115	Gabbia di biella (Asse accoppiamento)D.14xD.20x12	Big end cage (Crankpin) D.14xD.20x12	1	9,90
6	70001131	Gabbia di biella (Spinotto pistone) D.10xD.14x10	Small end cage (Piston pin) D.10xD.14x10	1	5,40

AQUASCOOTER AS650 -1-ONE - AS650 SUPERMAGNUM (disegno 2) - (drawing 2)

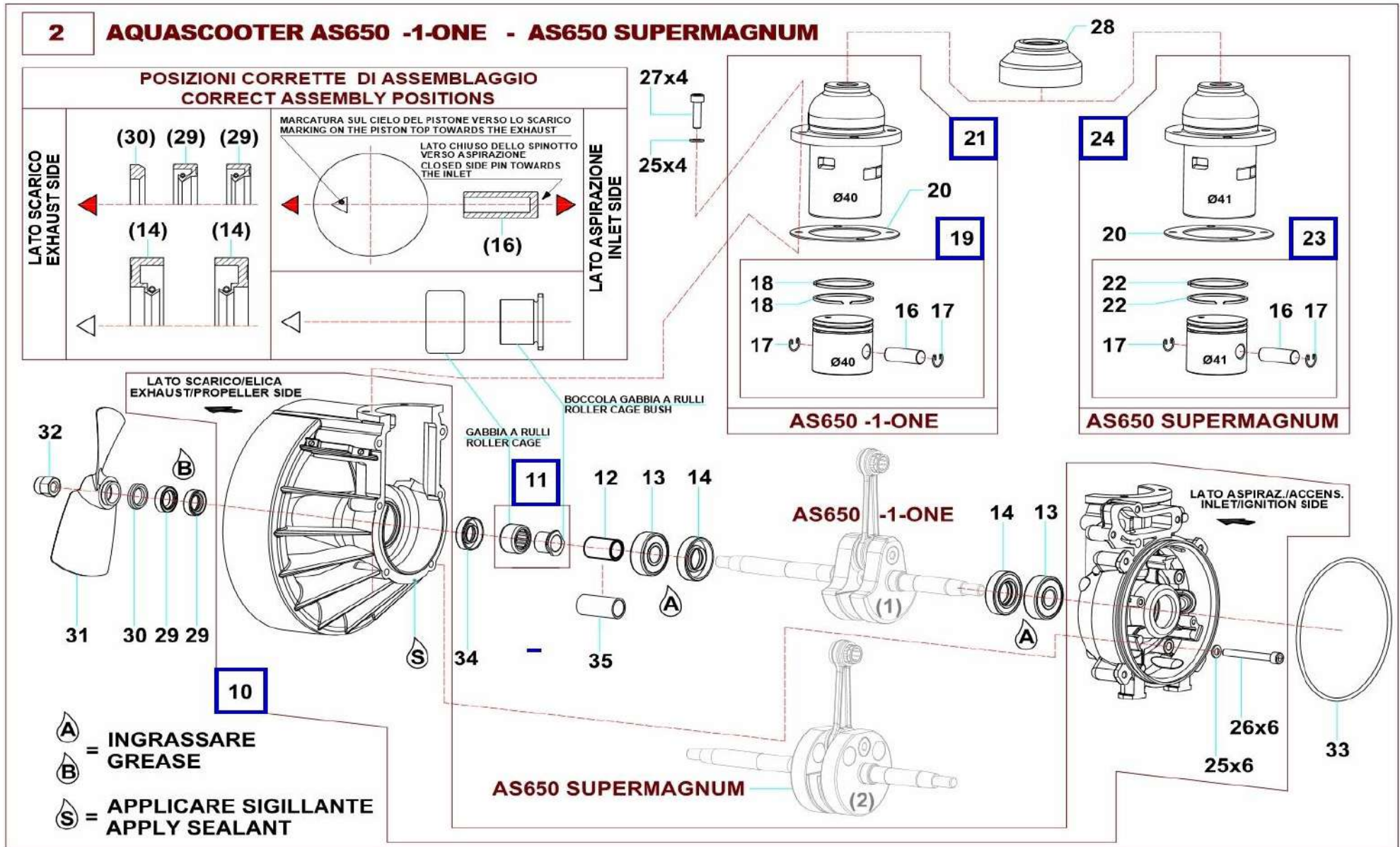

AQUASCOOTER AS650 -1-ONE - AS650 SUPERMAGNUM (disegno 2) - (drawing 2)

Pos.	Cod.	Descrizione	Description	Qt.	Unit Price €
10	70002020	Basamento motore con viti	Crankase with screw	1	135,00
11	70002037	Kit gabbia elica con boccola	Propeller cage kit with bush	1	15,00
12	70001126	Distanziale lato elica L=24,8 Enjoy INSERITO IN PRODUZIONE DA 01/03/2020	Spacer propeller side L=24.8 Enjoy POSTED IN PRODUCTION FROM 01/03/2020	1	3,00
13	70001090	Cuscinetto albero motore SKF 6201-2RSH/C3	Crankshaft bearing SKF 6201-2RSH/C3	2	5,40
14	70001092	Paraolio albero motore D.15xD.32x7	Crankshaft oil seal D.15xD.32x7	2	6,00
16	70001118	Spinotto pistone	Piston pin	1	6,00
17	70001116	Anellino ferma spinotto	Piston pin clip	2	0,50
18	70001119	Segmento pistone D.40 AS650 -1-ONE	AS650 -1-ONE Piston ring D.40	2	6,00
19	70001120	Pistone completo D.40 AS650 -1-ONE	AS650 -1-ONE Complete piston D.40	1	50,00
20	70001028	Guarnizione cilindro sp.0,8	Cylinder gasket 0,8 thickness	1	2,00
	70001162	Guarnizione cilindro sp.0,5	Cylinder gasket 0,5 thickness		2,00
21	70002035	Kit cilindro/pistone D.40 AS650 -1-ONE	AS650 -1-ONE Cylinder/piston kit D.40	1	140,00
22	70001144	Segmento pistone D.41 AS650 S.Magnum	AS650 S.Magnum piston ring D.41	2	8,00
23	70001142	Pistone completo D.41 AS650 S.Magnum	AS650 S.Magnum complete piston D.41	1	55,00
24	70002044	Kit cilindro/pistone D.41 AS650 S.Magnum	AS650 S.Magnum cylinder/piston kit D.41	1	160,00
25	70001018	Rondella piana D.5,4xD.10x1 INOX	Flat washer D.5,4xD.10x1 INOX	10	0,30
26	70001032	Vite TCEI M5x40 INOX	Screw TCEI M5x40 INOX	6	1,10
27	70001081	Vite TCEI M5x20 INOX	Screw TCEI M5x20 INOX	4	1,10
28	70001071	Cuffia cilindro	Cylinder cap	1	4,80
29	70001091	Paraolio D.12xD.19x5 doppio labbro	Oil seal D.12xD.19x5 double lip	2	5,00
30	70001086	Disco di protezione	Protection disc	1	1,00
31	70002004	Elica	Propeller	1	15,10
32	70001020	Dado cieco in ottone M8x15	Brass blind nut M8x15	1	2,10
33	70001088	O-Ring D.101,28xD.2,62 (3400)	O-Ring D.101,28xD.2,62 (3400)	1	3,00
34	70001198	Paraolio supplementere 21x12x4 Enjoy INSERITO IN PRODUZIONE DA 01/03/2020	Oil seal D.21x12x4 Enjoy POSTED IN PRODUCTION FROM 01/03/2020	1	5,00
35	70001125	Distanziale lato elica L=28.8 IN PRODUZIONE FINO AL 29/02/2020	Spacer propeller side L=28.8 IN PRODUCTION UP TO 29/02/2020	1	3,00

Le classi di selezione A-B-C di pistoni e cilindri sono solo per la lavorazione
Selection classes A-B-C of pistons and cylinders are valid for processing only

n°2 2020



AQUASCOOTER AS650 -1-ONE - AS650 SUPERMAGNUM (disegno 3) - (drawing 3)

3 AQUASCOOTER AS650 -1-ONE - AS650 SUPERMAGNUM

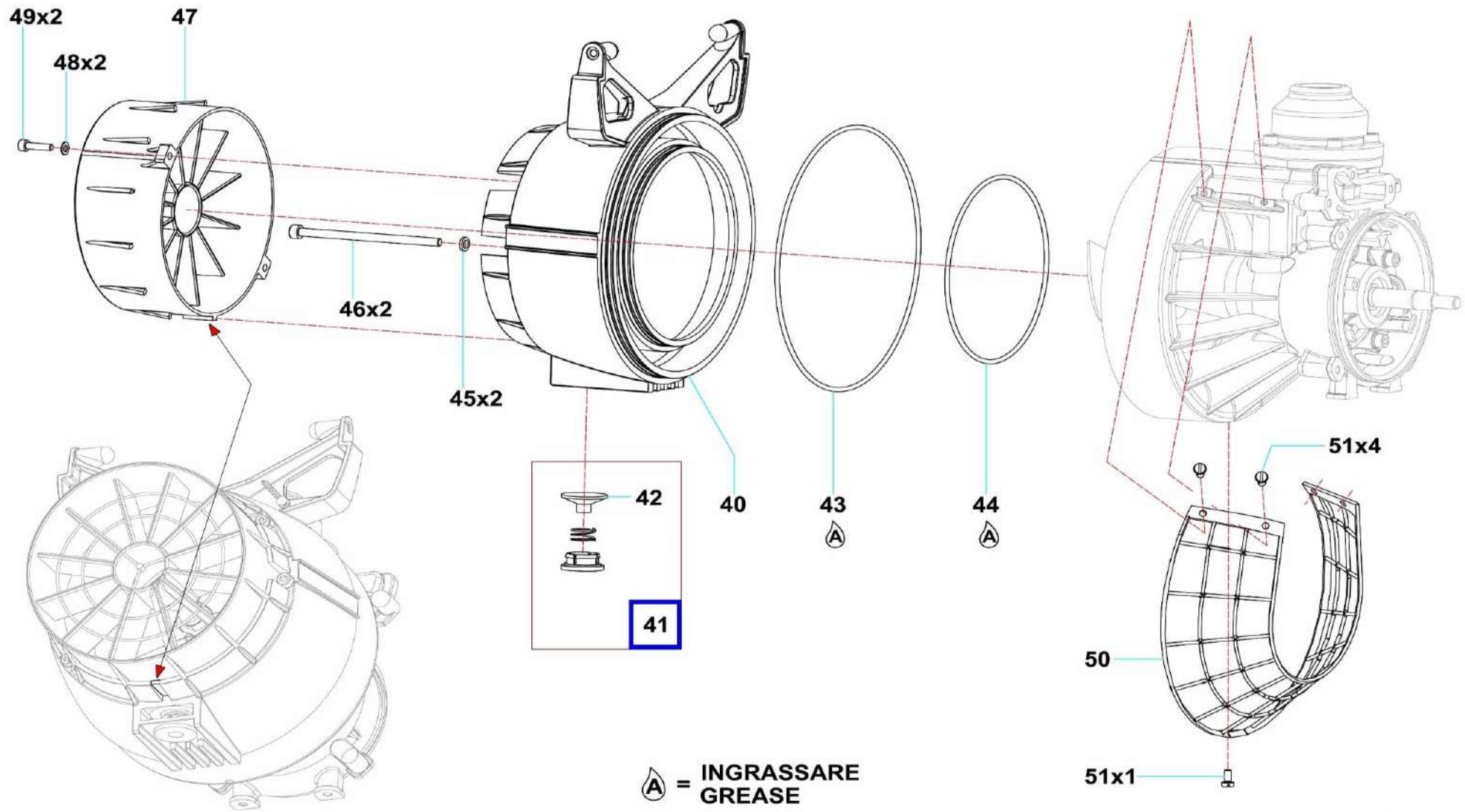

AQUASCOOTER AS650 -1-ONE - AS650 SUPERMAGNUM (disegno 3) - (drawing 3)

Pos.	Cod.	Descrizione	Description	Qt.	Unit Price €
40	70002026	Marmitta	Muffler	1	80,00
41	70002034	Kit valvola di scarico	Exhaust valve kit	1	9,00
42	70001101	Valvola di scarico	Exhaust valve	1	5,00
43	70001103	O-Ring D.152,07xD.2,62 (3600) esterno	O-Ring D.152,07xD.2,62 (3600) external	1	3,00
44	70001104	O-Ring D.113,98xD.2,62 (3450) interno	O-Ring D.113,96xD.2,62 (3450) internal	1	3,00
45	70001080	Rondella in rame D.5,3xD.9x1,4	Flat copper washer D.5,3xD.9x1,4	2	0,80
46	70001023	Vite TCEI M5x90 INOX	Screw TCEI M5x90 INOX	2	3,80
47	70001014	Convogliatore acqua lato elica	Propeller side water conveyor	1	12,00
48	70001031	Rondella piana D.4,4xD.8x0,8 INOX	Flat washer D.4,4xD.8x0,8 INOX	2	0,30
49	70001082	Vite TCEI M4x16 INOX	Screw TCEI M4x16 INOX	2	1,10
50	70001025	Griglia di protezione anteriore	Front protection grid	1	8,00
51	70001036	Vite TCIC M4x8 INOX	Screw TCIC M4x8 INOX	5	0,50

AQUASCOOTER AS650 -1-ONE - AS650 SUPERMAGNUM (disegno 4) - (drawing 4)

4 AQUASCOOTER AS650 - AS650 SUPERMAGNUM

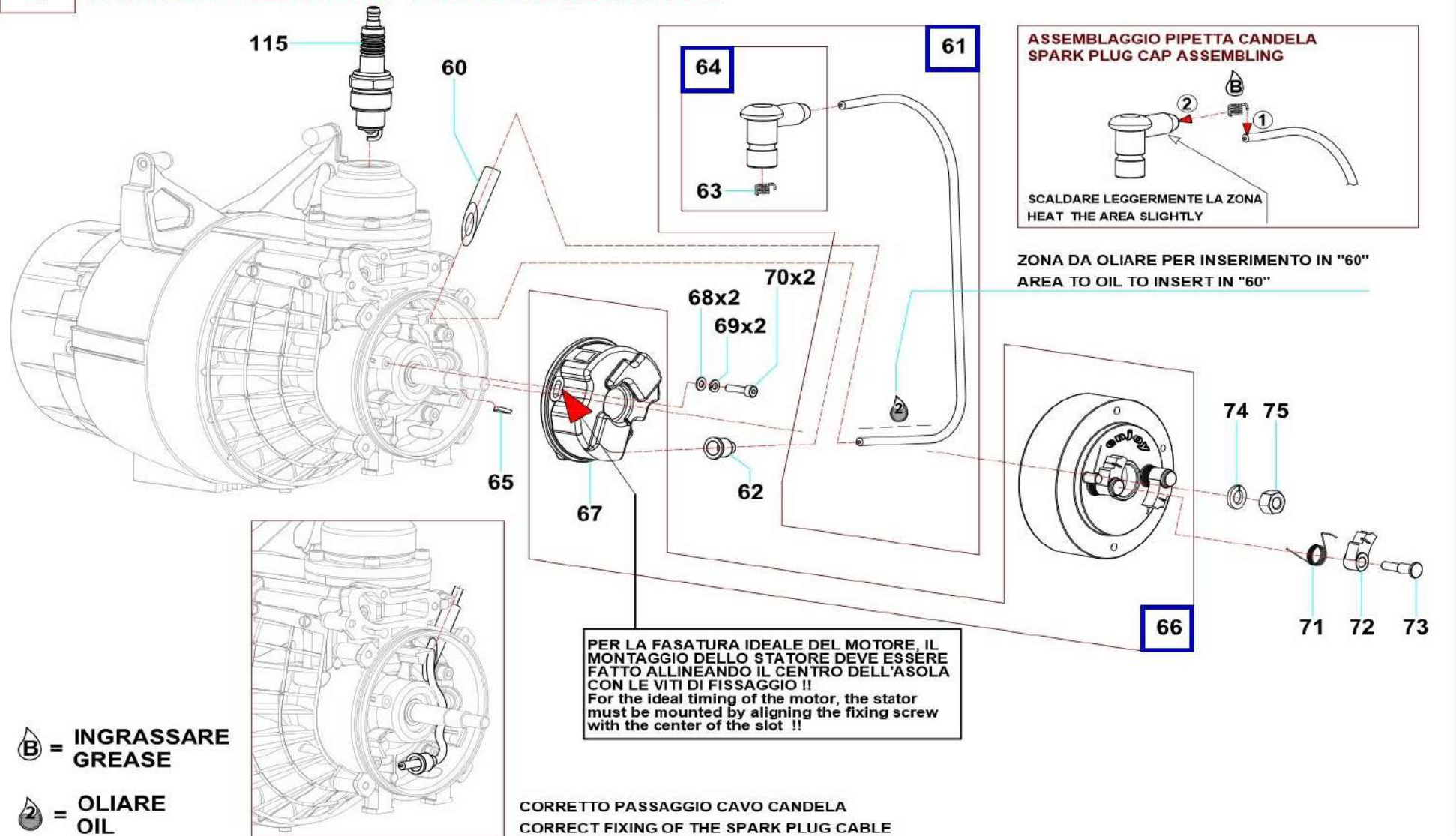

AQUASCOOTER AS650 -1-ONE - AS650 SUPERMAGNUM (disegno 4) - (drawing 4)

Pos.	Cod.	Descrizione	Description	Qt.	Unit Price €
60	70002019	Gommino passacavo	Rubber fairlead	1	2,20
61	70001136	Cavo candela completo di cappuccio	Complete spark plug cable with cap	1	13,80
62	70001098	Passacavo per cavo candela	Fairlead for spark plug cable	1	1,00
63	70001095	Molla per cappuccio candela	Spring for spark plug cap	1	1,00
64	70001093	Cappuccio candela con molla	Spark plug cap with spring	1	5,00
65	70001070	Linguetta a disco 2x4,4 C45	Disc tab 2x4,4 C45	1	2,00
66	70001132	Accensione elettronica completa	Complete electronic ignition	1	120,00
67	70001135	Statore/centralina	Stator/coil	1	60,00
68	70001031	Rondella piana D.4,4xD.8x0,8 INOX	Flat washer D.4,4xD.8x0,8 INOX	2	0,30
69	70001085	Grower D.4,4xD.7,4x1 INOX	Grower D.4xD.7,4x1 INOX	2	0,30
70	70001082	Vite TCEI M4x16 INOX	Screw TCEI M4x16 INOX	2	1,10
71	70001108	Molla arpioncino	Hook spring	2	1,60
72	70001109	Arpioncino	Hook	2	3,50
73	70001107	Perno arpioncino	Hook pin	2	3,50
74	70001084	Grower D.8,3xD.14,5x2 INOX	Grower D.8,3xD.14,5x2 INOX	1	0,30
75	70001040	Dado M8x6,3 esag.13 INOX	Nut M8x6,3 hexag.13 INOX	1	0,50
115	70001133*	Candela BOSCH	Spark plug BOSCH	1	10,50
	70001035*	Candela NGK	Spark plug NGK	1	8,50

* **Candele indifferentemente inserite nella busta attrezzi (Pos. 251) / Spark plugs indifferently inserted in the tools bag (Pos.251)**

AQUASCOOTER AS650 -1-ONE - AS650 SUPERMAGNUM (disegno 5) - (drawing 5)

5 AQUASCOOTER AS650 -1-ONE - AS650 SUPERMAGNUM

B = INGRASSARE
GREASE

INCLUSO NEL RICAMBIO CARBURATORE
INCLUDED IN THE SPARE PART CARBURETTOR

(197)

RIMUOVERE PER SETTARE GLI SPILLI
REMOVE TO SET THE NEEDLES

SCHEMA DI SMONTAGGIO PER LA SOSTITUZIONE DEI
PARTICOLARI: 86 - 87 - 88
DISASSEMBLING SCHEME TO REPLACE PARTS: 86 - 87 - 88

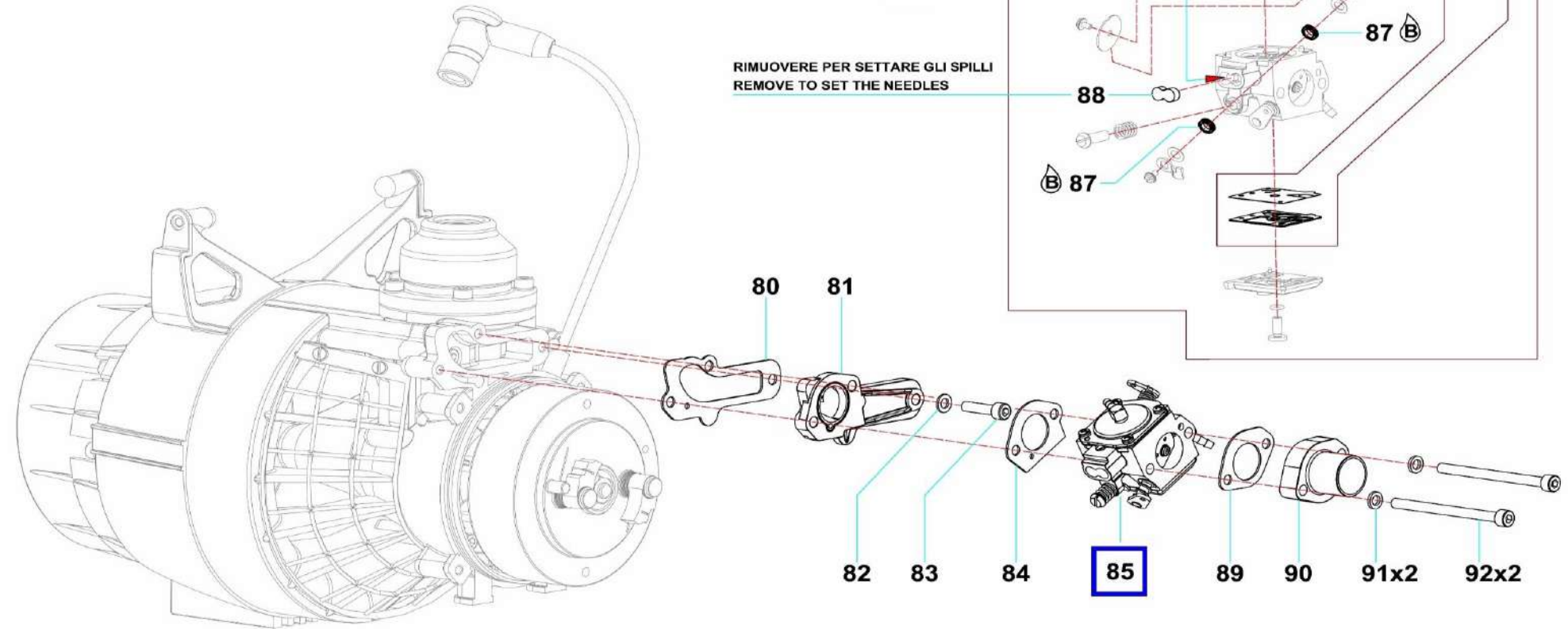

AQUASCOOTER AS650 -1-ONE - AS650 SUPERMAGNUM (disegno 5) - (drawing 5)

Pos.	Cod.	Descrizione	Description	Qt.	Unit Price €
80	70001074	Guarnizione flangia carburatore	Carburettor gasket flange	1	2,00
81	70002015	Flangia carburatore	Carburettor flange	1	10,80
82	70001018	Rondella piana D.5,4xD.10x1 INOX	Flat washer D.5,4xD.10x1 INOX	1	0,30
83	70001081	Vite TCEI M5x20 INOX	Screw TCEI M5x20 INOX	1	1,10
84	70001076	Guarnizione carburatore	Carburettor gasket	1	1,50
85	70001128	Carburatore (con chiave spilli Pos.197)	Carburettor (with needles key Pos.197)	1	118,00
86	70001122	Kit membrane WALBRO	Walbro membranes kit	1	18,00
87	70001172	Anello tenuta Walbro asse farfalla gas	Walbro rubber seal for throttle gas axle	2	2,60
88	70001145	Tappo in gomma protezione spilli	Rubber cap for needles protection	1	1,80
89	70001077	Guarnizione collettore aspirazione	Intake collector gasket	1	1,50
90	70002017	Collettore aspirazione	Intake collector	1	9,00
91	70001080	Rondella in rame D.5,3xD.9x1,4	Flat copper washer D.5,3xD.9x1,4	2	0,80
92	70001073	Vite TCEI M5x65 INOX	Screw TCEI M5x65 INOX	2	2,10
197	70001124	Chiave in plastica per carburazione	Plastic key for carburetion needles	1	4,30

AQUASCOOTER AS650 -1-ONE - AS650 SUPERMAGNUM (disegno 6) - (drawing 6)

6 AQUASCOOTER AS650 ONE - AS650 SUPERMAGNUM

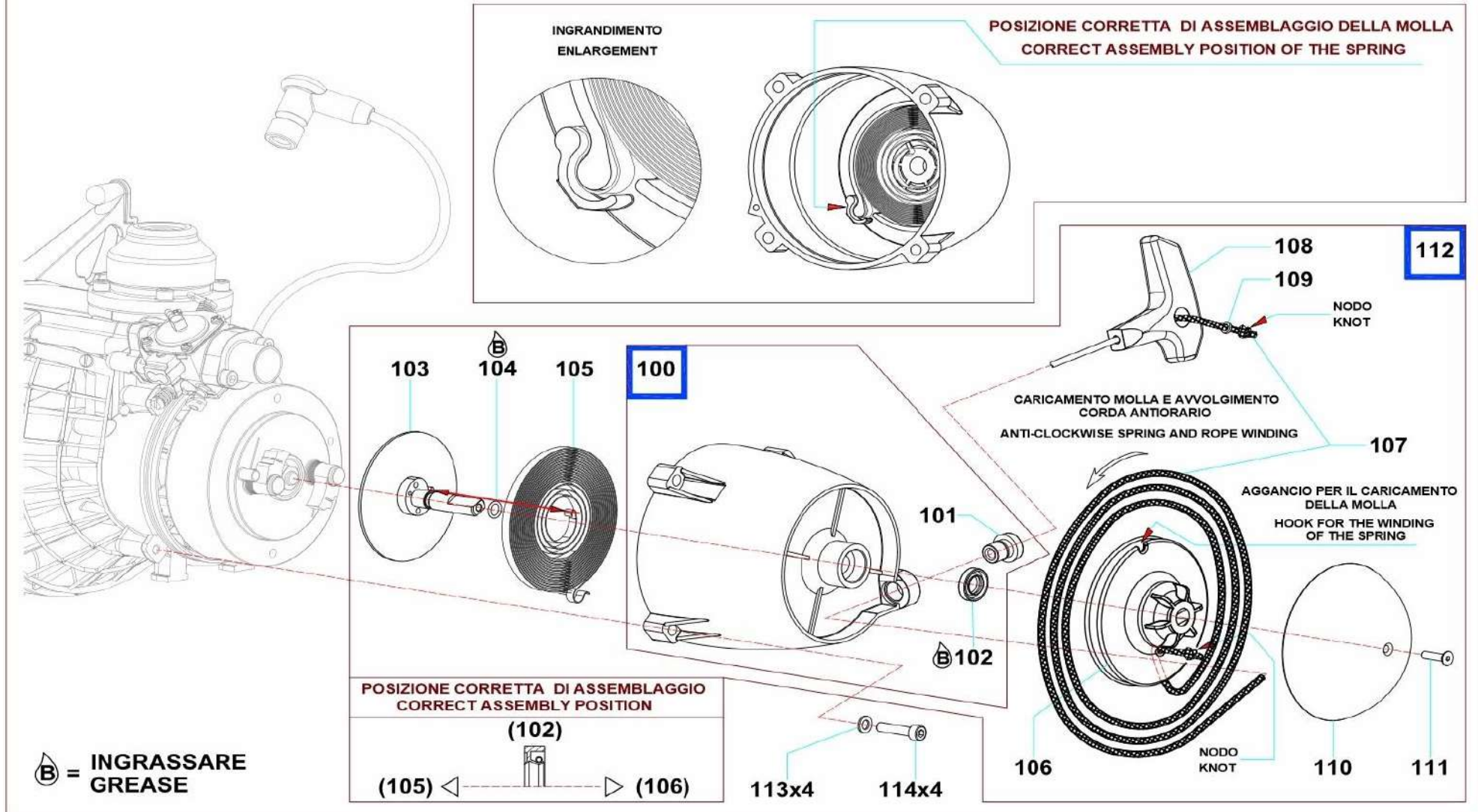

AQUASCOOTER AS650 -1-ONE - AS650 SUPERMAGNUM (disegno 6) - (drawing 6)

Pos.	Cod.	Descrizione	Description	Qt.	Unit Price €
100	70002040	Scatola avviamento con paraolio	Starter box with oil seal	1	20,00
101	70001044	Boccola per fune	Bush for rope	1	3,60
102	70001050	Paraolio D.10xD.18x4 doppio labbro	Oil seal D.10xD.18x4 double lip	1	5,00
103	70001047	Puleggia avviamento con perno	Starter pulley with axle	1	12,90
104	70001062	O-Ring D.6,5xD.1,5 per perno puleggia avviamento	O-Ring D.6,5xD.1,5 for starter pulley axle	1	0,50
105	70001051	Molla avviamento	Starter spring	1	10,50
106	70001046	Puleggia avviamento	Starter pulley	1	10,80
107	70002009	Fune avviamento L=133cm.	Starter rope L=133cm.	1	2,20
108	70001052	Impugnatura avviamento	Starter handle	1	4,30
109	70001053	Anellino ferma nodo	Stop knot ring	1	0,40
110	70001045	Calotta scatola avviamento	Starter case shell	1	3,20
111	70001049	Vite TSPEI M4x16 INOX (svasata)	Screw TSPEI M4x16 INOX (countersunk)	1	1,10
112	70002007	Avviamento completo	Complete starter	1	44,00
113	70001018	Rondella piana D.5,4xD.10x1 INOX	Flat washer D.5,4xD.10x1 INOX	4	0,30
114	70001022	Vite TCEI M5x25 INOX	Screw TCEI M5x25 INOX	4	1,10

O-Ring D.6,5xd.1,5 per pin starting pulley

AQUASCOOTER AS650 -1-ONE - AS650 SUPERMAGNUM (disegno 7) - (drawing 7)

7 AQUASCOOTER AS650 -1-ONE - AS650 SUPERMAGNUM

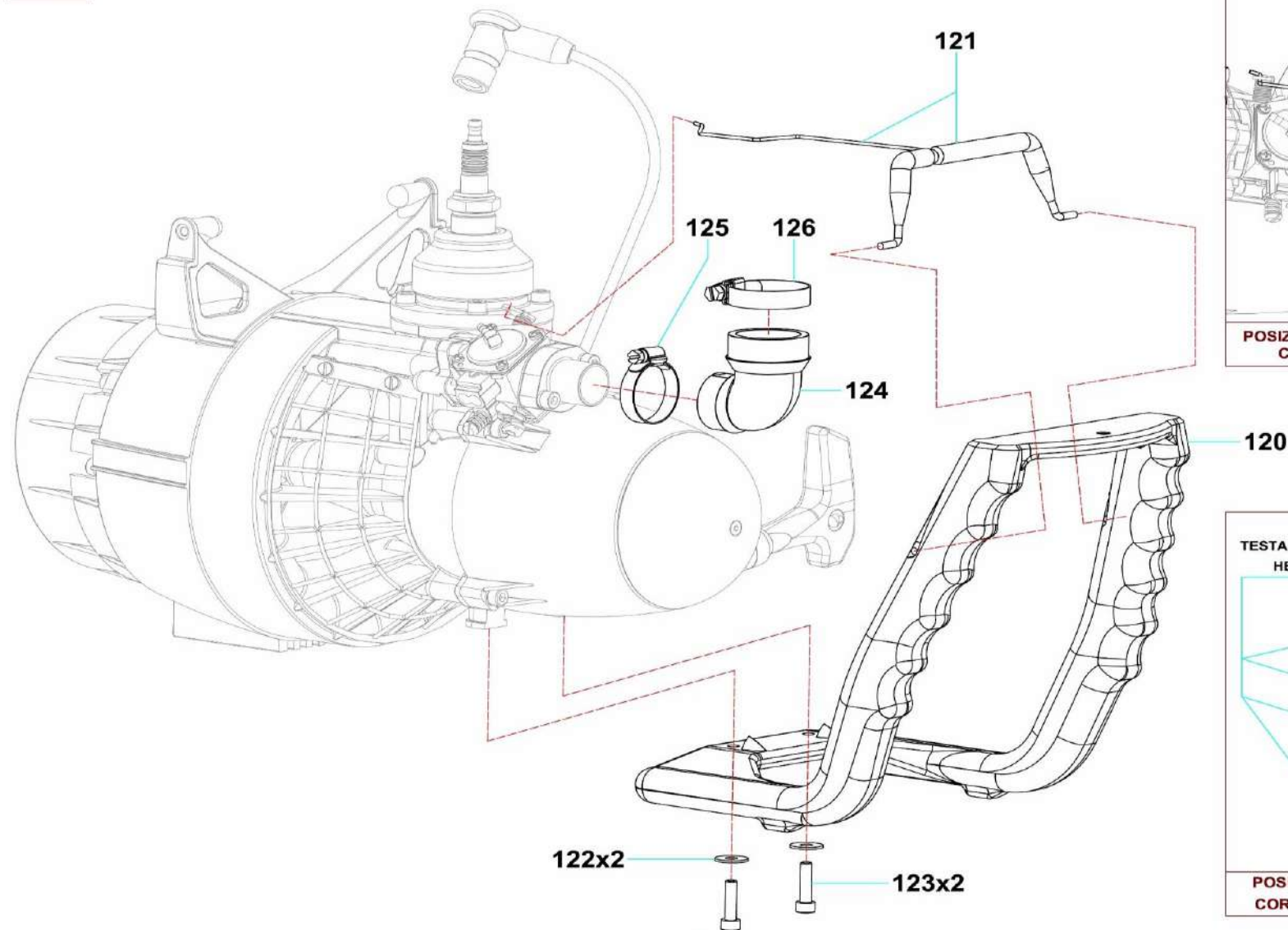

AQUASCOOTER AS650 -1-ONE - AS650 SUPERMAGNUM (disegno 7) - (drawing 7)

Pos.	Cod.	Descrizione	Description	Qt.	Unit Price €
120	70001016	Impugnatura	Handle	1	19,40
121	70002006	Leva acceleratore completa	Complete throttle lever	1	13,50
122	70001021	Rondella piana D.5,4xD.15x1 INOX	Flat washer D.5,4xD.15x1 INOX	2	0,30
123	70001081	Vite TCEI M5x20 INOX	Screw TCEI M5x20 INOX	2	1,10
124	70001055	Raccordo aspirazione in gomma	Rubber suction fitting	1	10,00
125	70001034	Fascetta a vite 16-25 W4	Screw clamp 16-25 W4	1	4,30
126	70001056	Fascetta a vite 20-32 W4	Screw clamp 20-32 W4	1	4,30

AQUASCOOTER AS650 -1-ONE - AS650 SUPERMAGNUM (disegno 8) - (drawing 8)

8 AQUASCOOTER AS650 -1-ONE - AS650 SUPERMAGNUM

130

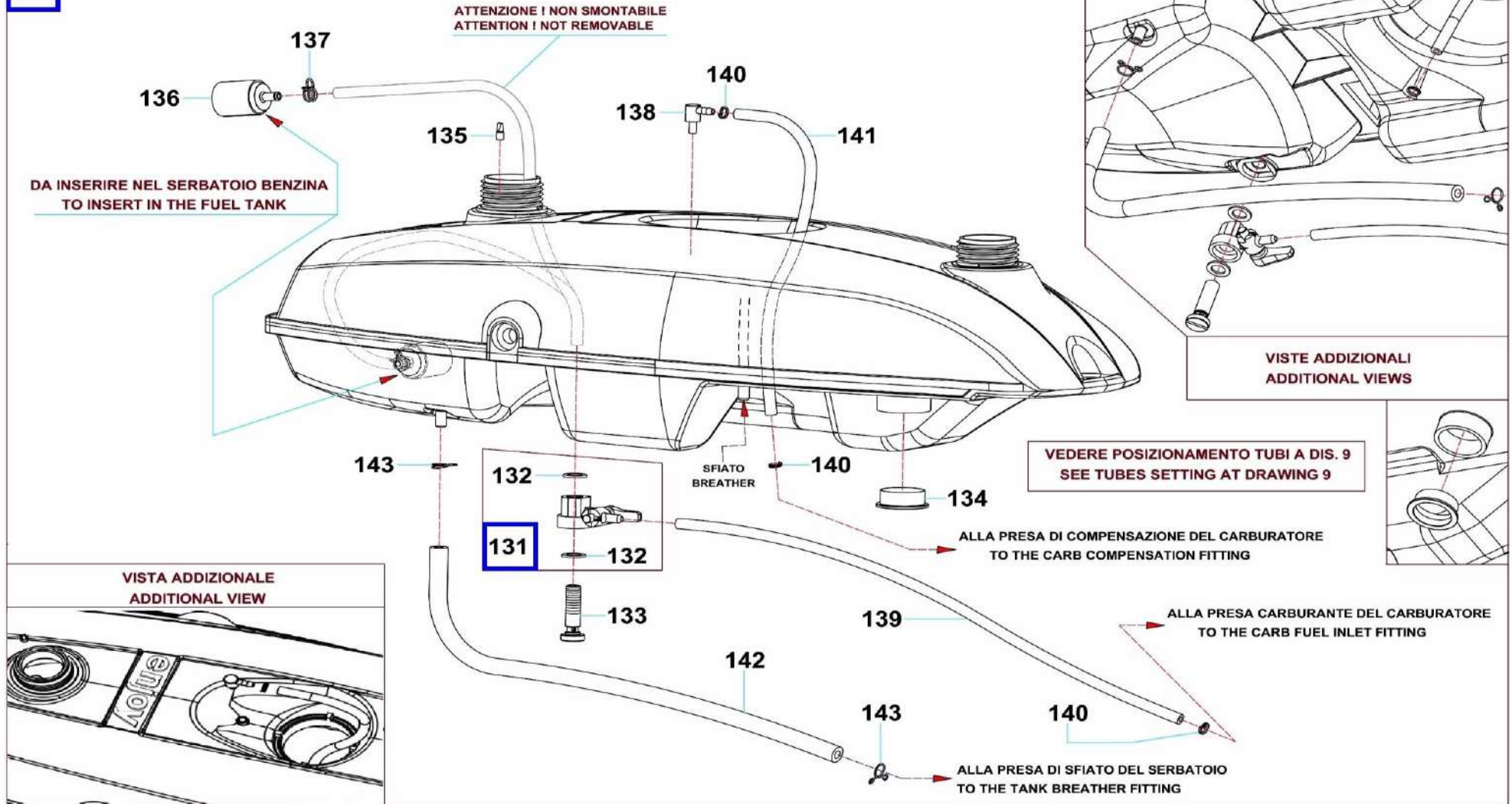

AQUASCOOTER AS650 -1-ONE - AS650 SUPERMAGNUM (disegno 8) - (drawing 8)

<i>Pos.</i>	<i>Cod.</i>	<i>Descrizione</i>	<i>Description</i>	<i>Qt.</i>	<i>Unit Price €</i>
130	70002010	Serbatoio completo con Pos.131-132-133-134-135-138 con adesivi avvertenze (Pos.170)	Complete tank with Pos.131-132-133-134-135-138 with warnings stickers (Pos.170)	1	110,00
131	70002033	Rubinetto carburante con guarnizioni	Fuel tap with gasket	1	12,90
132	70001065	Guarnizione rubinetto carburante	Fuel tap gasket	2	0,50
133	70001066	Vite rubinetto carburante in INOX	INOX fuel tap screw	1	5,00
134	70001063	Boccola serbatoio	Fuel tank bush	1	5,00
135	70001039	Valvola sfiato serbatoio carburante	Fuel tank breather valve	1	3,80
136	70001061	Pesca carburante con filtro	Fuel pick up body with filter	1	6,50
137	70002012	Fascetta bifilare a molla D.7,3-7,8	Two-wire spring clamp D.7,3-7,8	1	0,60
138	70001069	Raccordo in plastica a 90°	Plastic 90° fitting	1	2,40
139	70000006	Tubo nero carburante D.3,2xD.6,4 L=300mm	Black fuel tube D.3,2xD.6,4 L=300mm	1	2,50
140	70001068	Fascetta a molla D.6	Spring clamp D.6	3	0,30
141	70000003	Tubo nero compensaz. D.3,2xD.6,4 L=200mm	Black compensation tube D.3,2xD.6,4 L=200mm	1	2,20
142	70001054	Tubo sfiato D.5xD.10 L= 330mm	Light breather tube D.5xD.10 L=330mm	1	3,20
143	70001072	Fascetta a molla D.8	Spring clamp D.8	2	0,30

AQUASCOOTER AS650 -1-ONE - AS650 SUPERMAGNUM (disegno 9) - (drawing 9)

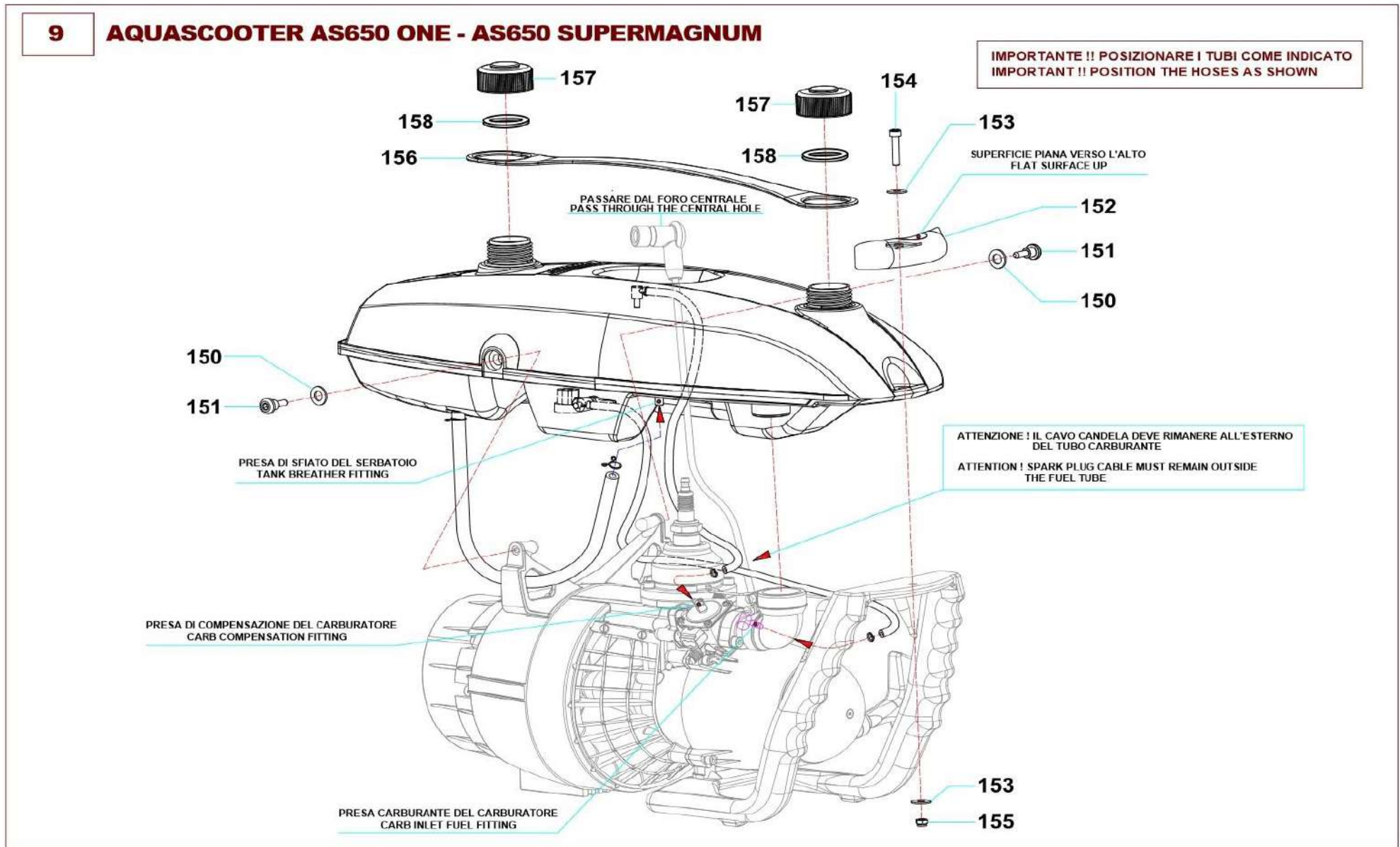

AQUASCOOTER AS650 -1-ONE - AS650 SUPERMAGNUM (disegno 9) - (drawing 9)

Pos.	Cod.	Descrizione	Description	Qt.	Unit Price €
150	70001037	Rondella piana D.8,5xD.16x1,5 INOX	Flat washer D.8,5xD.16x1,5 INOX	2	0,30
151	70001024	Vite INOX fissaggio laterale serbatoio	Lateral INOX screw for tank fixing	2	4,50
152	70002046	Paracolpi in gomma	Rubber bumper	1	10,80
153	70001021	Rondella piana D.5,4xD.15x1 INOX	Flat washer D.5,4xD.15x1 INOX	2	0,30
154	70001022	Vite TCEI M5x25 INOX	Screw TCEI M5x25 INOX	1	1,10
155	70001019	Dado autobloccante M5x5 INOX	Self lock nut M5x5 INOX	1	0,30
156	70001017	Manico di trasporto	Carry handle	1	6,00
157	70002005	Tappo serbatoio	Tank cap	2	8,00
158	70001026	Guarnizione tappo serbatoio	Tank cap gasket	1	3,00

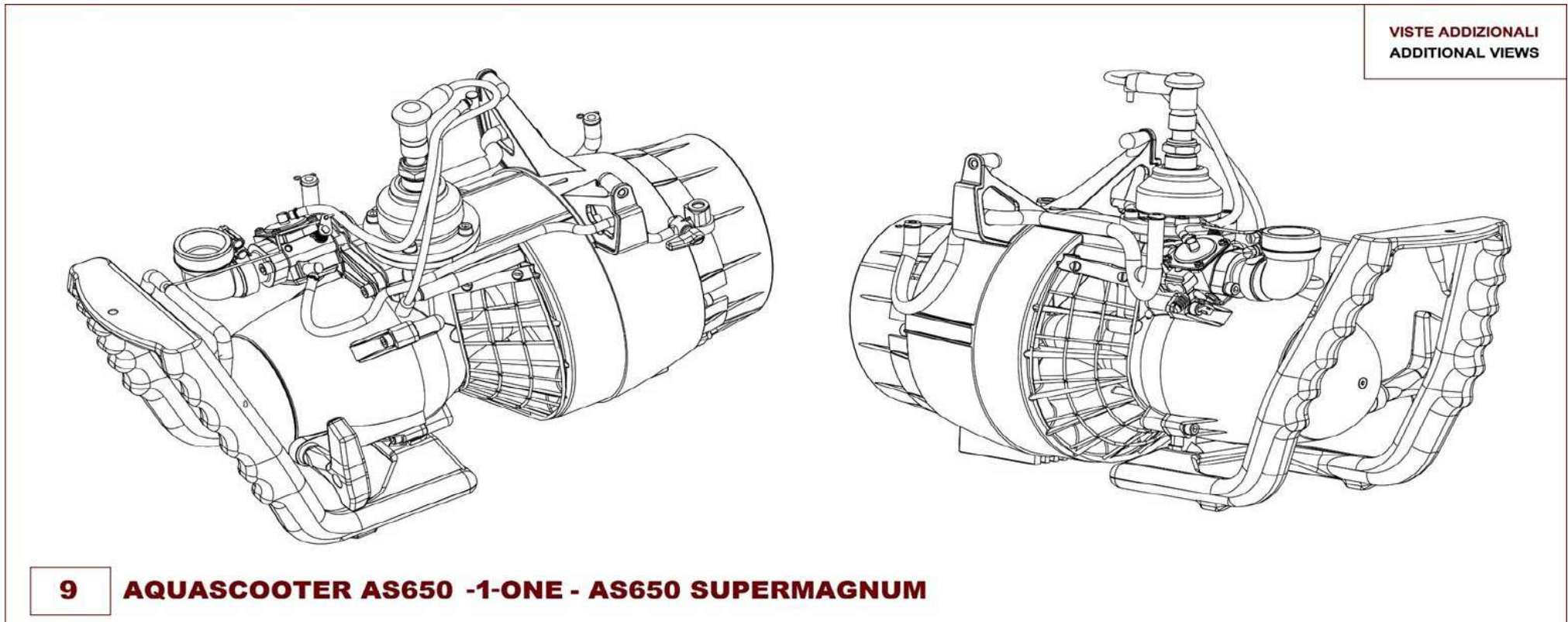

AQUASCOOTER AS650 ONE - AS650 SUPERMAGNUM (disegno 10) - (drawing 10)

10 AQUASCOOTER AS650 ONE - AS650 SUPERMAGNUM

IMPORTANTE !! PER MONTARE LO SNORKEL, SVITARE IL TAPPO CAMERA ASPIRAZIONE E AVVITARE A FONDO LA GHIERA GIALLA DELLO SNORKEL

IMPORTANT !! TO ASSEMBLE THE SNORKEL, UNSCREW THE SUCTION CHAMBER CAP AND SCREW DEEPLY THE YELLOW RING NUT OF THE SNORKEL

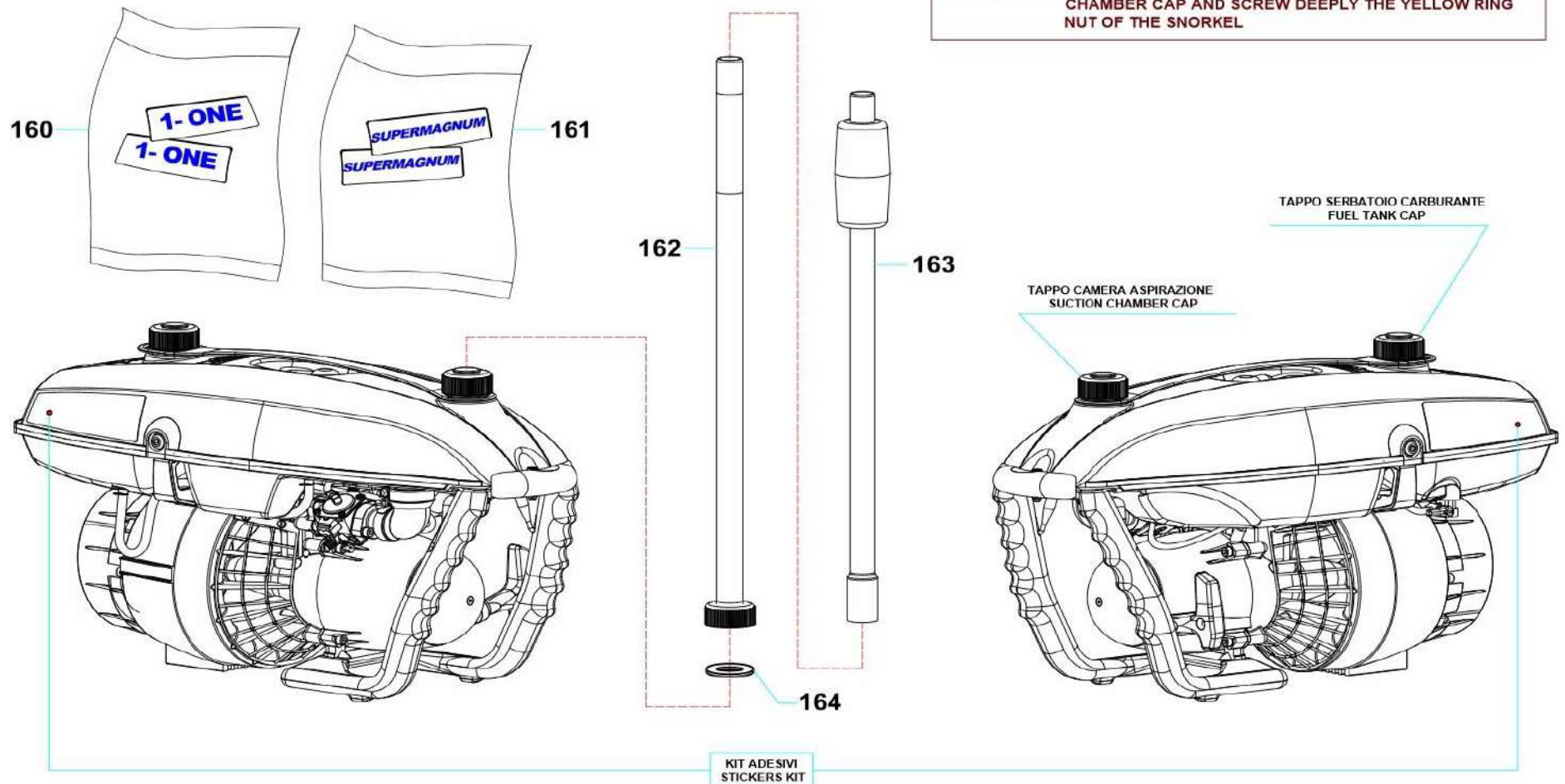

AQUASCOOTER AS650 -1-ONE - AS650 SUPERMAGNUM (disegno 10) - (drawing 10)

Pos.	Cod.	Descrizione	Description	Qt.	Unit Price €
160	70001169	Coppia adesivi AS650 -1-ONE	Pair of stickers AS650 -1-ONE	1	8,00
161	70001170	Coppia adesivi AS650 SUPERMAGNUM	Pair of stickers AS650 SUPERMAGNUM	1	8,00
162	70002001	Snorkel	Snorkel	1	14,50
163	70002002	Prolunga snorkel	Snorkel extension	1	12,00
164	70001006	Guarnizione snorkel	Snorkel gasket	1	3,00

KIT ADESIVI AVVERTENZE - WARNING STICKERS KIT

KIT ADESIVI AVVERTENZE - WARNINGS STICKERS KIT AQUASCOOTER AS650 -1-ONE - AS650 SUPERMAGNUM

170

LATO POSTERIORE AQUASCOOTER
AQUASCOOTER REAR SIDE

AVVIAMENTO - START - STOP

RUN - MARCIA

AIR - INTAKE

OIL 1% BIOSYNT

APERTO (ON) / CHIUSO (OFF)

IMPORTANTI!!!
LA CARBURAZIONE DEVE ESSERE SEMPRE ABBONDANTE, PER AVERE LA MASSIMA POTENZA.

IMPORTANT!!!
CARBURATION HAS TO BE RICH, TO HAVE THE MAXIMUM POWER.





IMPORTANTI!!!
CAMBIARE LA VALVOLA DI CARICO OIL CHANGE VALVE 2 TIMES PER YEAR.

ATTENZIONE!!!
Dopo l'uso, accendere l'Aquascooter per svuotare i residui di acqua. (VEDI LIBRETTO ISTRUZIONI) CHE CONTIENE I DATI DI ACCENSIONE E LA VOCE PER SVUOTARE I RESIDUI DI ACQUA. (SEE SERVICE MANUAL) FOR STARTING AND TO EMPTY THE REMAINS OF WATER.

ATTENTION!!!
AFTER USING THE AQUASCOOTER, PLEASE TURN IT ON TO EMPTY THE REMAINS OF WATER THAT MAY HAVE ACCUMULATED IN THE AIR CHAMBER TO AVOID SEVERE DAMAGE FROM MOISTURE.

IMPORTANT!!!
VERY IMPORTANT!!! AFTER EACH USE, TURN YOUR AQUASCOOTER OFF AND START IT UP AGAIN TO EMPTY THE REMAINS OF WATER FROM THE AIR CHAMBER.

LATO ANTERIORE AQUASCOOTER
AQUASCOOTER FRONT SIDE

KIT ADESIVI AVVERTENZE - WARNING STICKERS KIT

Pos.	Cod.	Descrizione	Description	Qt.	Unit Price €
170	70001013	Kit adesivi avvertenze	Warning stickers kit	1	10,00

ATTENZIONE !! GLI ADESIVI AVVERTENZE SONO UGUALI PER ENTRAMBI I MODELLI AS650 -1-ONE - AS650 SUPERMAGNUM E DEVONO ESSERE SEMPRE TUTTI INTEGRI DURANTE L'USO DELL'AQUASCOOTER

ATTENTION !! THE WARNING STICKERS ARE THE SAME FOR BOTH MODELS AS650 -1-ONE - AS650 SUPERMAGNUM AND THEY ALL MUST BE ALWAYS INTACT DURING THE AQUASCOOTER USE

ATTENZIONE !! SEGUIRE LO SCHEMA DI PAG. 27 PER L'APPLICAZIONE DEGLI ADESIVI AVVERTENZE

ATTENTION !! FOLLOW THE SCHEME AT PAG. 27 FOR THE WARNING STICKERS APPLICATION

KIT GUARNIZIONI E LUBRIFICANTI - GASKET KITS AND LUBRICANTS

KIT GUARNIZIONI E LUBRIFICANTI - GASKET KITS AND LUBRICANTS

AQUASCOOTER AS650 -1-ONE - AS650 SUPERMAGNUM

180

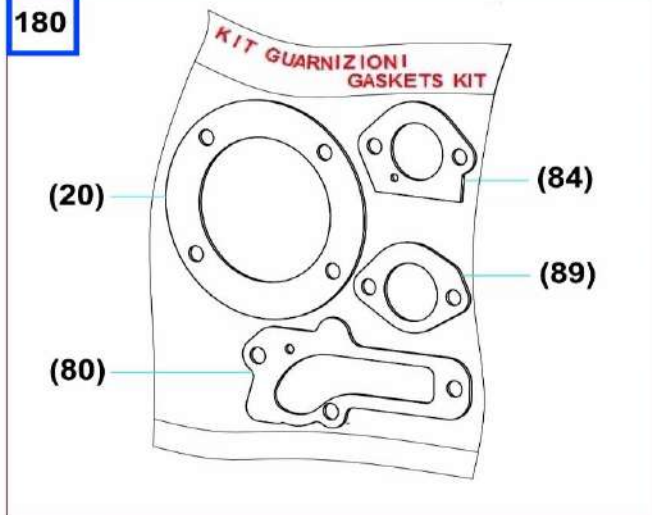

181

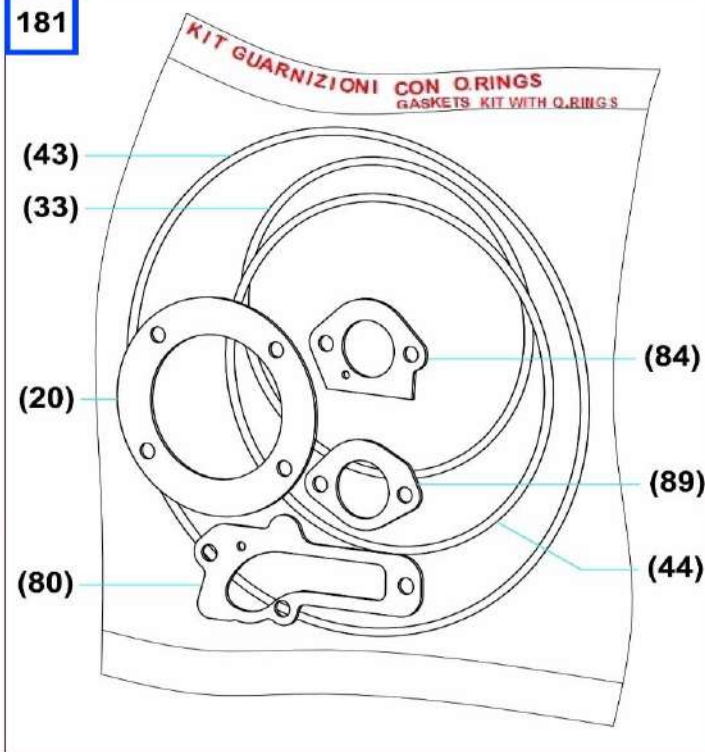

183



182



184

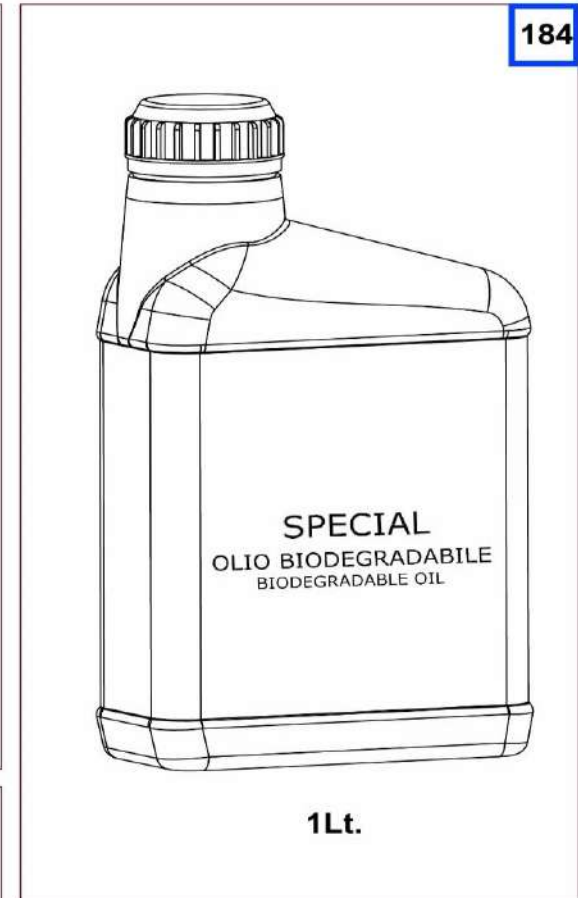

KIT GUARNIZIONI E LUBRIFICANTI - GASKET KITS AND LUBRICANTS

Pos.	Cod.	Descrizione	Description	Qt.	Unit Price €
180	70001137	Kit guarnizioni	Gaskets kit	1	7,00
181	70002030	Kit guarnizioni con O.Rings	Gasket kit with O.Rings	1	15,00
182	75009002	Flacone da 30ml. di olio Aquascooter per miscela 2T,biodegradabile, sintetico	30ml. Aquascooter oil bottle for 2T mixture biodegradable, synthetic	1	2,20
183	75009001	Flacone da 140ml. di olio Aquascooter per miscela 2T, biodegradabile sintetico	140ml. Aquascooter oil bottle for 2T mixture biodegradable, synthetic	1	7,00
184	75009004	Bottiglia da 1Lt. di olio Aquascooter per miscela 2T,biodegradabile sintetico	1Lt Aquascooter oil bottle for 2T mixture biodegradable, syntetic	1	24,00

ATTREZZI PER MONTAGGIO E SETTAGGIO - ASSEMBLING AND SETTING TOOLS

ATTREZZI PER MONTAGGIO E SETTAGGIO - ASSEMBLING AND SETTING TOOLS

AQUASCOOTER AS650 -1-ONE - AS650 SUPERMAGNUM

190

Tampone montaggio gabbia a rulli elica
Propeller cage assembling buffer

Tampone montaggio paraolio lato elica pos. 34
Oil seal propeller side pos.34 assembling buffer



192

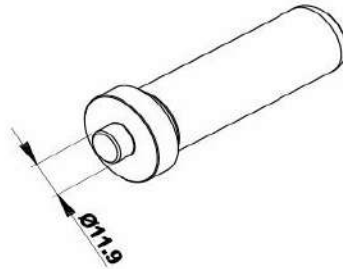

193

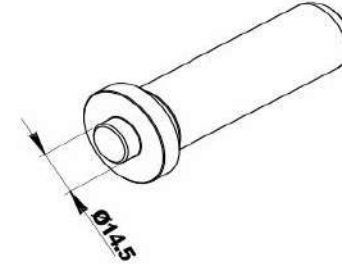

194

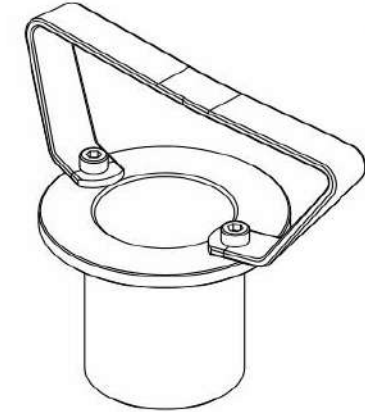

191

195

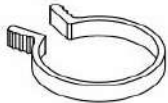

196

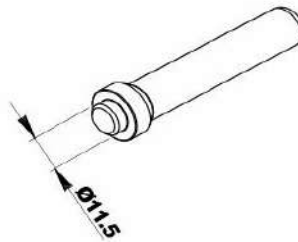

197



PLASTICA - PLASTIC MADE

198

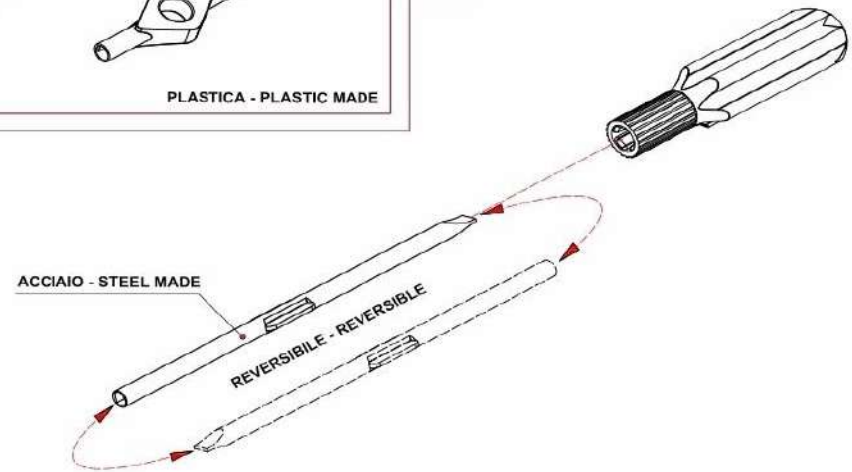

ATTREZZI PER MONTAGGIO E SETTAGGIO - ASSEMBLING AND SETTING TOOLS

Pos.	Cod.	Descrizione	Description	Qt.	Unit Price €
190	70002048	Tampone montaggio gabbia a rulli elica	Propeller cage assembling buffer	1	30,00
191	71000004	Tampone montaggio 3° paraolio lato elica pos.34	3rd oil seal propeller side pos.34 assembling buffer	1	30,00
192	70001000	Tampone montaggio cuscinetti albero motore	Crankshaft bearings assembling buffer	1	15,00
193	71000001	Tampone montaggio paraoli albero motore	Crankshaft oil seals assembling buffer	1	15,00
194	70001139	Boccola chiusura basamento	Crankcase closing bush	1	80,00
195	70001164	Attrezzo chiusura segmenti pistone	Piston rings closing tool	1	3,80
196	71000003	Tampone montaggio paraoli elica	Propeller oil seals assembling buffer	1	15,00
197	70001124	Chiave in plastica per carburazione	Plastic key for carburetion needles	1	4,30
198	70001153	Chiave in acciaio per carburazione	Steel key for carburetion needles	1	18,00

ATTREZZI MONTAGGIO / SMONTAGGIO E TEST - ASSEMBLING / DISASSEMBLING AND TEST TOOLS

AQUASCOOTER AS650 -1-ONE - AS650 SUPERMAGNUM

200

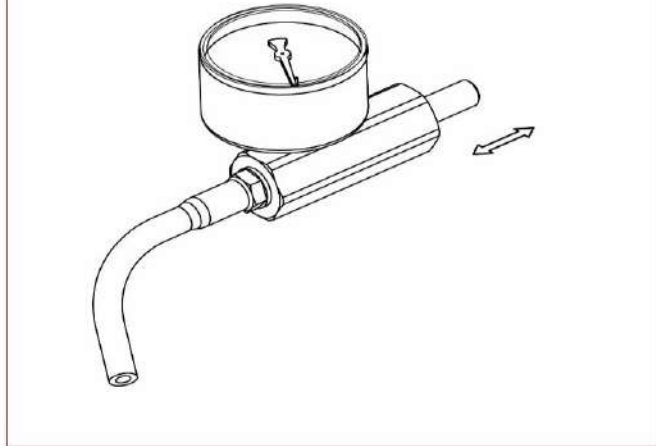

201

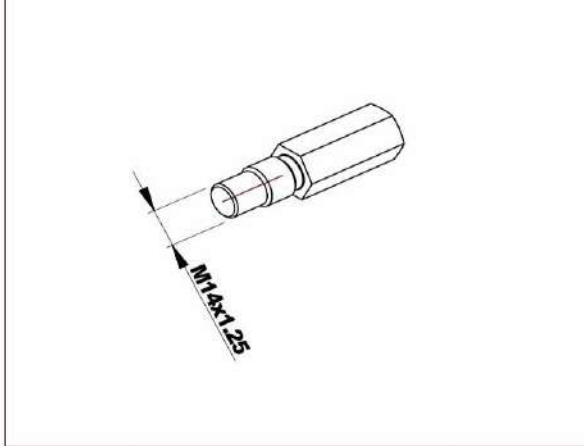

202

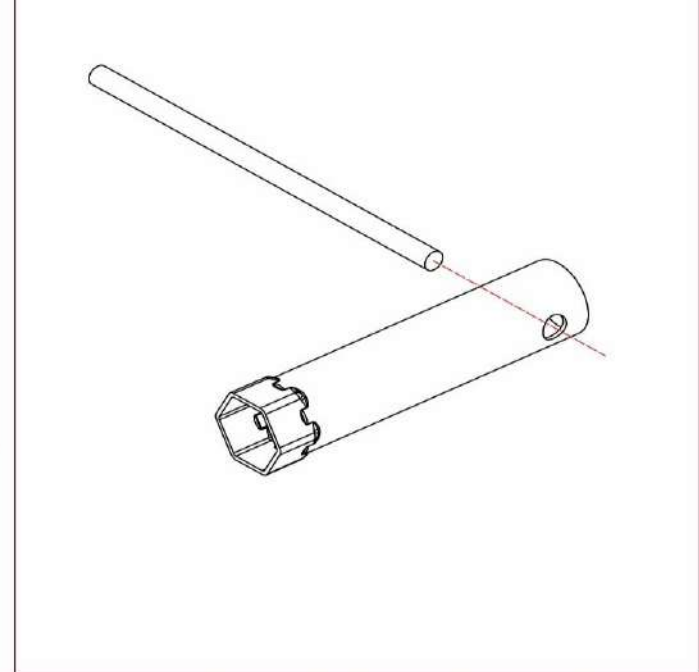

203

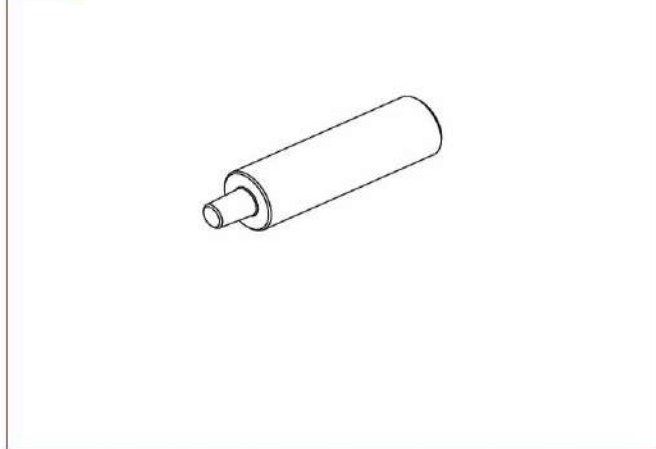

ATTREZZI MONTAGGIO/SMONTAGGIO E TEST - ASSEMBLING/DISASSEMBLING AND TEST TOOLS

Pos.	Cod.	Descrizione	Description	Qt.	Unit Price €
200	70002051	Prova tenuta carburatore 0÷1bar (0÷14psi)	Carburettor pressure tester 0÷1bar (0÷14psi)	1	38,40
201	70002052	Perno ferma pistone	Piston stop pin	1	5,60
202	70001171	Chiave candela L=120mm	Spark plug key L=120mm	1	4,80
203	70002041	Tampone scarico	Muffler buffer	1	10,80

ATTREZZI PER SMONTAGGIO - DISASSEMBLING TOOLS

ATTREZZI PER SMONTAGGIO - DISASSEMBLING TOOLS

AQUASCOOTER AS650 -1-ONE - AS650 SUPERMAGNUM

210

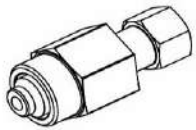

211

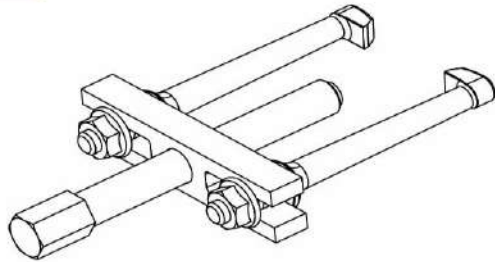

212

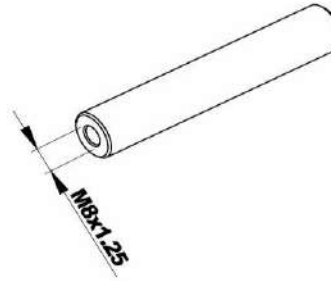

213

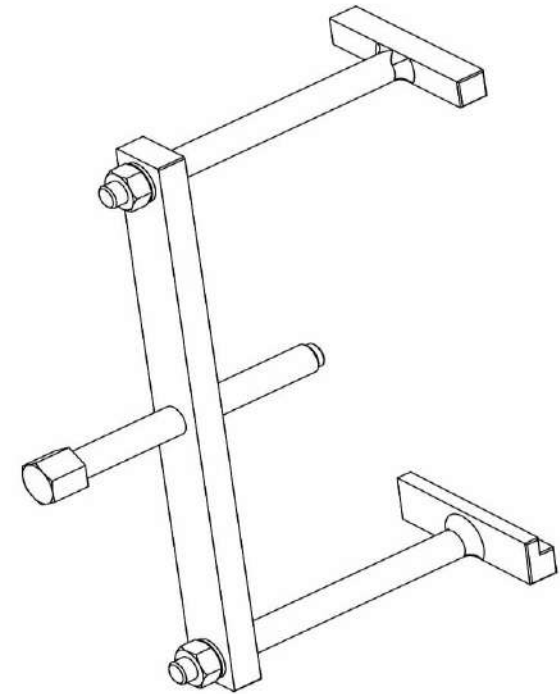

214

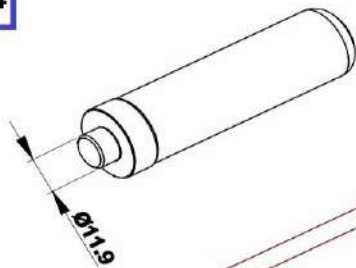

215

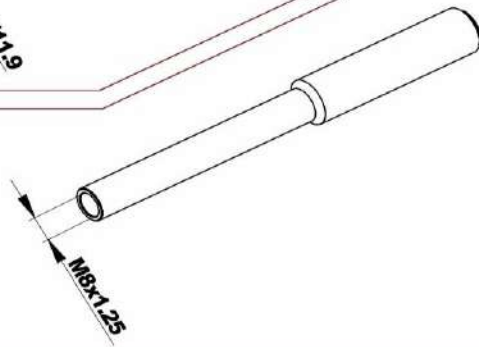

216

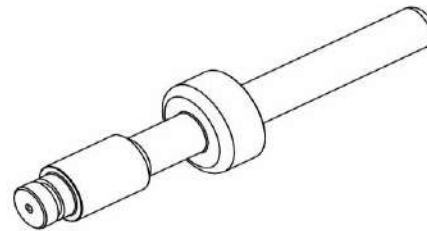

217

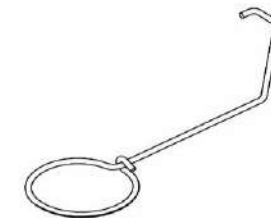

ATTREZZI PER SMONTAGGIO - DISASSEMBLING TOOLS

Pos.	Cod.	Descrizione	Description	Qt.	Unit Price €
210	70001130	Estrattore volano	Flywheel puller	1	19,40
211	70002036	Estrattore elica	Propeller puller	1	53,90
212	70009995	Attrezzo sblocca elica	Propeller unlock tool	1	10,50
213	70002031	Estrattore marmitta	Muffler puller	1	64,60
214	71000002	Tampone smontaggio cuscinetto lato volano	Ignition side bearing disassembly buffer	1	15,00
215	70009998	Attrezzo estrazione albero motore	Crankshaft extraction tool	1	15,00
216	70009997	Attrezzo estrazione gabbia elica	Propeller cage extraction tool	1	22,00
217	70009996	Attrezzo estrazione pesca serbatoio	Fuel tank pick up extraction tool	1	6,30

ACCESSORI 1 - ACCESSORIES 1

ACCESSORI 1 - ACCESSORIES 1 AQUASCOOTER AS650 -1-ONE AS650 SUPERMAGNUM

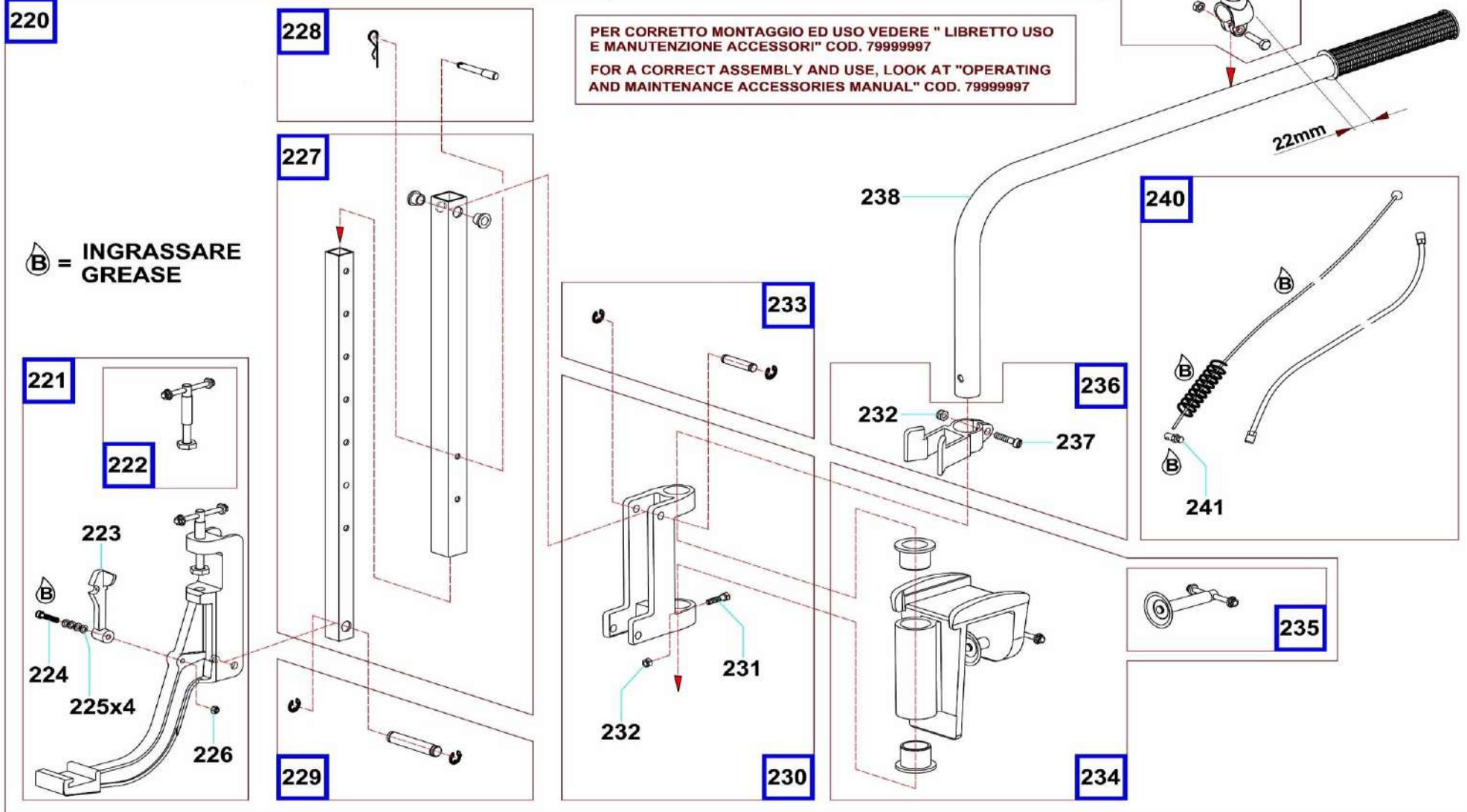

ACCESSORI 1 - ACCESSORIES 1

Pos.	Cod.	Descrizione	Description	Qt.	Unit Price €
220	72009001	Attacco barca completo (inscatolato con manuale di uso e manutenz. A PAG. 45 e 49)	Complete boat bracket (boxed with operating and maintenance manual at PAG. 45 and 49)	1	284,50
221	72002018	Staffa sommersa completa	Complete submerged bracket	1	74,80
222	72001016	Morsetto completo INOX per staffa sommersa	Complete INOX clamp for submerged bracket	1	19,50
223	72001014	Leva acceleratore	Throttle lever	1	6,20
224	70001032	Vite TCEI M5x40 INOX	Screw TCEI M5x40 INOX	1	1,10
225	70001018	Rondella piana D.5,4xD.10x1 INOX	Flat washer D.5,4xD.10x1 INOX	4	0,30
226	70001019	Dado autobloccante M5x5 INOX	Self lock nut M5x5 INOX	1	0,30
227	72002017	Braccio telescopico completo	Complete telescopic arm	1	37,70
228	72002015	Perno con copiglia	Pin with cotter pin	1	5,40
229	72002016	Perno staffa sommersa con seeger E-CLIP	Submerged bracket pin with E-CLIP seegers	1	5,40
230	72002019	Canotto timone completo	Complete rudder tube	1	43,00
231	72001008	Vite TE M6x45 INOX	Screw TE M6x45 INOX	1	1,20
232	72001007	Dado autobloccante M6x6 INOX	Self lock nut M6x6 INOX	2	0,60
233	72002014	Perno canotto timone con seeger E-CLIP	Rudder tube pin with E-CLIP seegers	1	6,50
234	72002020	Supporto completo per specchio di poppa	Complete mounting bracket for boat transom	1	88,20
235	72001015	Morsetto completo INOX per supporto sp. po.	Complete INOX clamp for mounting bracket	1	25,60
236	72002021	Supporto di bloccaggio braccio telescopico	Locking support for telescopic arm	1	5,40
237	72001025	Vite TCIC M6x20 INOX	Screw TCIC M6x20 INOX	1	0,60
238	72002001	Barra timone completa	Complete tiller	1	21,50
239	72001001	Comando acceleratore	Throttle control	1	8,70
240	72002022	Cavo acceleratore completo	Complete throttle wire	1	12,30
241	72001009	Morsetto cavo acceleratore	Throttle cable clamp	1	2,00

ACCESSORI 2 - ACCESSORIES 2 AQUASCOOTER AS650 -1 ONE - AS650 SUPERMAGNUM

253

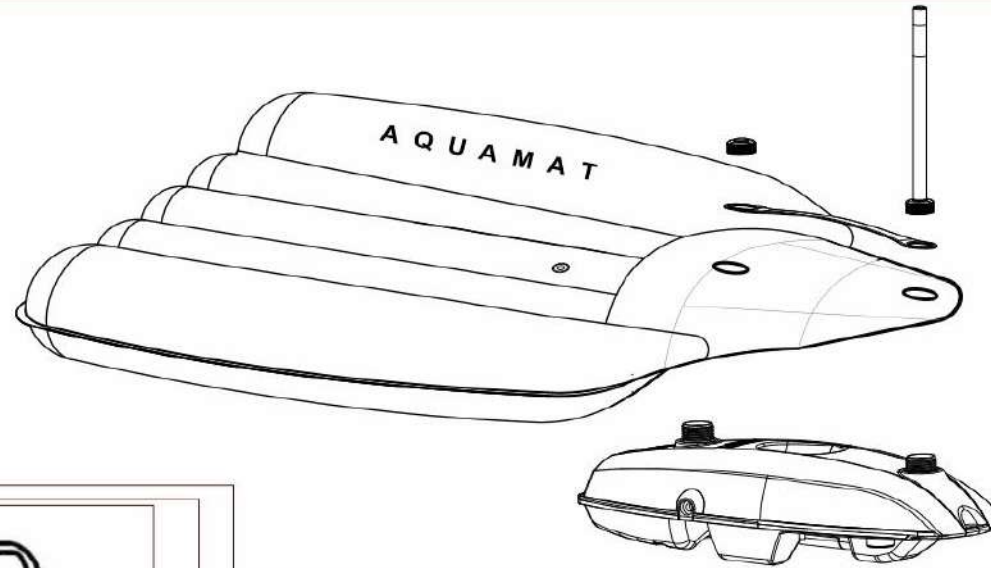

2021 NEW

257



250

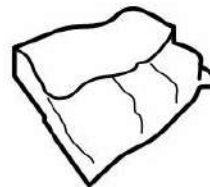

SENZA ATTREZZI
WITHOUT TOOLS

251

CON ATTREZZI
WITH TOOLS

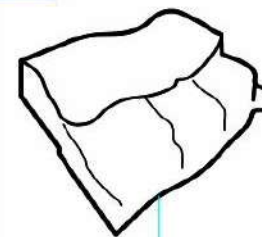

(250)

252



(202)



(197)



(115)



(182)

NGK

(107)



ACCESSORI 2 - ACCESSORIES 2

<i>Pos.</i>	<i>Cod.</i>	<i>Descrizione</i>	<i>Description</i>	<i>Qt.</i>	<i>Unit Price €</i>
250	70001011	Busta attrezzi vuota	Tools bag only	1	6,80
251	70001010	Busta attrezzi completa	Complete tools bag	1	30,00
252	75009005	Imbuto con filtro per carburante	Fuel funnel with filter	1	4,50
253	72109001	Materassino ad aria NEW 2021	Complete air mattress NEW 2021	1	83,50
257	70109001	Borsa AQUASCOOTER	AQUASCOOTER Bag	1	50,00

NUMERO DI SERIE, MANUALI E AVVERTENZE - SERIAL NUMBER, MANUALS AND WARNINGS



ATTENZIONE : I NUMERI DI SERIE SUL SERBATOIO, SUL CARTER MARMITTA E SUL CERTIFICATO DI GARANZIA DEVONO SEMPRE CORRISPONDERE

ATTENTION : THE SERIAL NUMBERS ON THE FUEL TANK, ON THE MUFFLER CASE AND ON THE WARRANTY CERTIFICATE MUST ALWAYS MATCH

Fronte / Front

Retro/Back

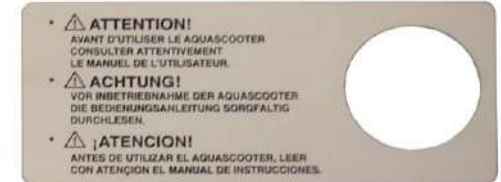

**CARTONCINO AVVERTENZE SOTTO TAPPO SERBATOIO
WARNINGS CARDBOARD UNDER FUEL CAP**



**MANUALE USO E MANUTENZIONE CARTACEO
OPERATING AND MAINTENANCE PRINT MANUAL**

NUMERO DI SERIE, MANUALI E AVVERTENZE - SERIAL NUMBER, MANUALS AND WARNINGS

Cod.	Descrizione	Description	Unit Price €
79999999	Manuale di uso e manutenzione cartaceo AQUASCOOTER AS650 -1-ONE AQUASCOOTER AS650 SUPERMAGNUM	Operating and maintenance print manual AQUASCOOTER AS650 -1-ONE AQUASCOOTER AS650 SUPERMAGNUM	8,50

ATTENZIONE : OGNI IMBALLO CONTIENE IL PROPRIO LIBRETTO USO E MANUTENZIONE CARTACEO
ATTENTION : EACH PACKAGE CONTAINS OWN USE AND MAINTENANCE PRINT MANUAL

79999996	Cartoncino avvertenze sotto tappo serbatoio	Warnings cardboard under fuel tank cap	1,50
----------	---------------------------------------------	----------------------------------------	-------------

ATTENZIONE : I MANUALI RICHIESTI PER MAIL O SCARICATI DAL SITO WEB SONO ESENTI DA COSTO
ATTENTION : THE MAUALS REQUESTED BY E-MAIL OR DOWNLOADED FROM THE WEB SITE ARE FREE OF COST

CONTENUTO IMBALLO AQUASCOOTER AS650 -1-ONE - AQUASCOOTER AS650 -1-ONE PACKAGING CONTENT

COD. 70009005



COD. 70001010 (POS. 251)



COD. 70002001 (POS. 162)

COD. 70002002 (POS. 163)

AQUASCOOTER AS 650 -1-ONE



COD. 79999999
MANUALE USO E MANUTENZIONE CARTACEO AQUASCOOTER AS 650 -1-ONE
MANUALE USO E MANUTENZIONE CARTACEO AQUASCOOTER AS 650 SUPERMAGNUM
OPERATING AND MAINTENANCE PRINT MANUAL AQUASCOOTER AS 650 -1-ONE
OPERATING AND MAINTENANCE PRINT MANUAL AQUASCOOTER AS 650 SUPERMAGNUM

CERTIFICATO DI GARANZIA
WARRANTY CERTIFICATE

CONTENUTO IMBALLO AQUASCOOTER AS 650 SUPERMAGNUM

AQUASCOOTER AS 650 SUPERMAGNUM PACKAGING CONTENT

COD. 70009007



COD. 70001010 (POS. 251)



COD. 70002001 (POS. 162)

COD. 70002002 (POS. 163)

AQUASCOOTER AS 650 SUPERMAGNUM



COD. 79999999 **MANUALE USO E MANUTENZIONE CARTACEO AQUASCOOTER AS 650 -1-ONE**
MANUALE USO E MANUTENZIONE CARTACEO AQUASCOOTER AS 650 SUPERMAGNUM
OPERATING AND MAINTENANCE PRINT MANUAL AQUASCOOTER AS 650 -1-ONE
OPERATING AND MAINTENANCE PRINT MANUAL AQUASCOOTER AS 650 SUPERMAGNUM



CERTIFICATO DI GARANZIA
WARRANTY CERTIFICATE

CONTENUTO IMBALLO ATTACCO BARCA - BOAT BRACKET PACKAGING CONTENT

COD. 72009001 (POS.220)

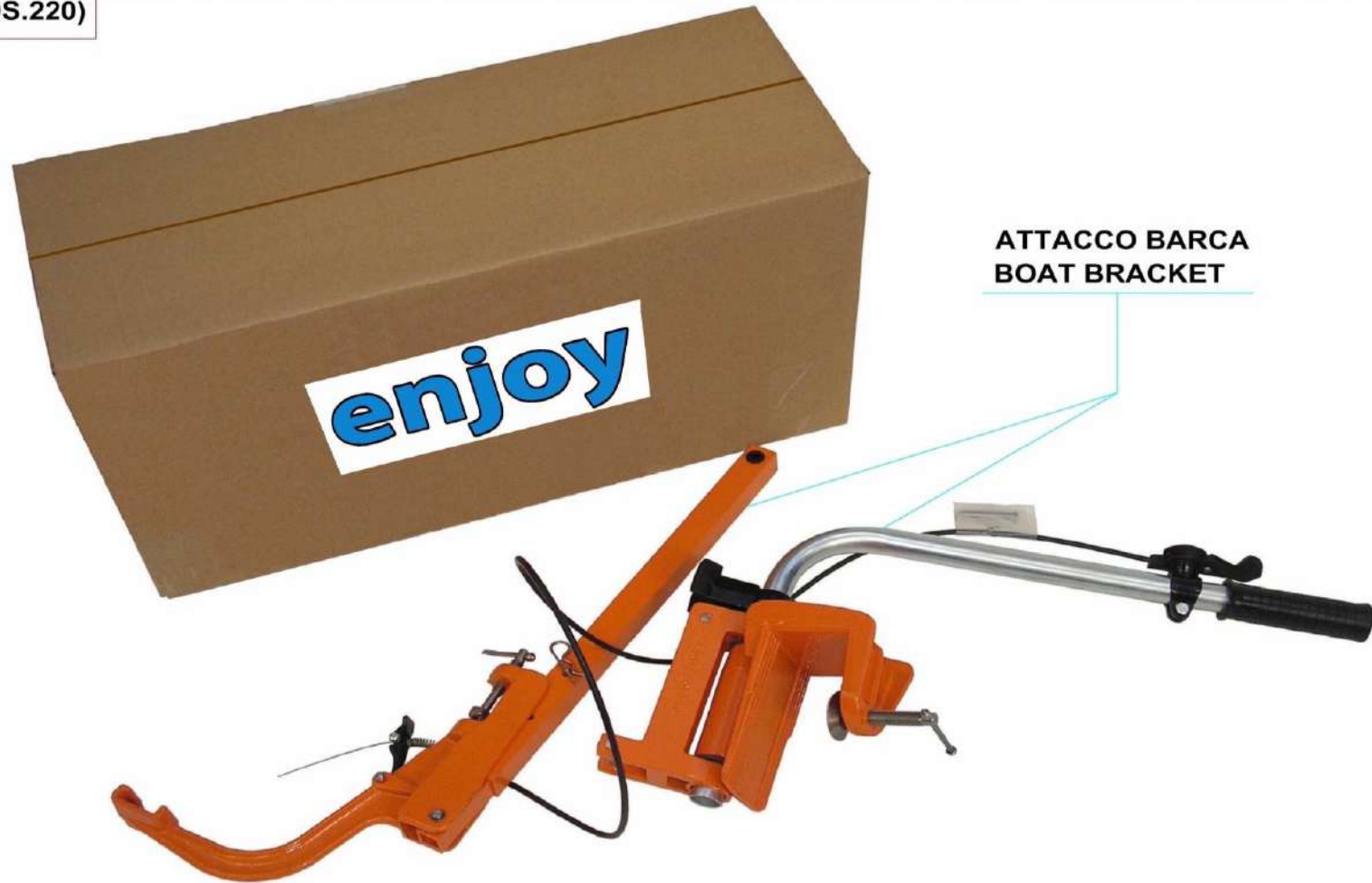

CONTENUTO IMBALLO MATERASSINO GONFIABILE - AIR MATTRESS PACKAGING CONTENT

COD. 72109001 (POS. 253)



**MATERASSINO GONFIABILE
AIR MATTRESS**

GALLERIA - GALLERY



enjoy

NOTE - NOTES

A series of horizontal dotted lines for writing notes.

COD.	DESCRIZIONE	DESCRIPTION	UNIT PRICE (€)	BOX SIZES WxDxH (cm)	PESO - WEIGHT (Kg.)
70009005	AQUASCOOTER AS 650 -1-ONE	AQUASCOOTER AS 650 -1-ONE	800,00	57.5x22x32.5	9.5
70009007	AQUASCOOTER AS 650 SUPERMAGNUM	AQUASCOOTER AS 650 SUPERMAGNUM	925,00	57.5x22x32.5	9.5
72009001	ATTACCO BARCA	BOAT BRACKET	284,50	59x22,5x34	4.5
72109001	MATERASSINO AQUAMAT	AIR MATTRESS AQUAMAT	83,50	59x22,5x34	3

ENJOY s.a.s.

Via Storchi ,2/b,
42011 – San Tomaso di Bagnolo in Piano (Reggio Emilia) – Italy.

Tel. **+39 0522 706329** P.IVA 02865810358

Web site : www.aquascooter.it E-mail : info@aquascooter.it

ENJOY s.a.s. si riserva il diritto di effettuare modifiche ai propri prodotti e ai propri prezzi in qualsiasi momento e senza preavviso. ENJOY s.a.s. non si ritiene responsabile per eventuali differenze fra informazioni del catalogo e i relativi prodotti.

I prezzi indicati sono IVA ESCLUSA e franco fabbrica.

ENJOY s.a.s. reserves the right to make modifications on the products and on the prices at any moment without notice.

ENJOY s.a.s. is not responsible for eventual differences between the catalogue information and the products.

The indicated prices are without VAT and ex-works.



MADE IN ITALY

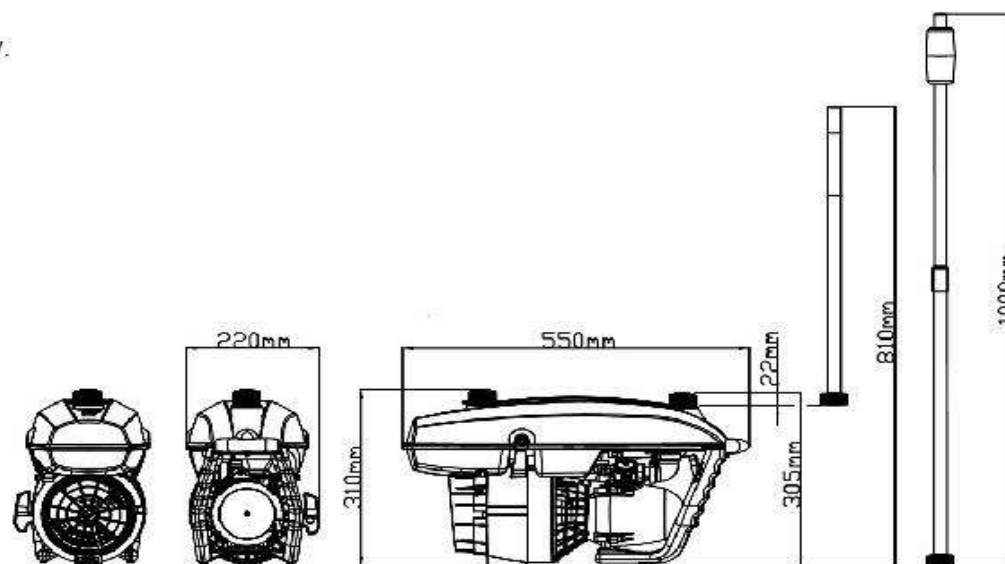

DIMENSIONI DI INGOMBRO - OVERALL SIZES